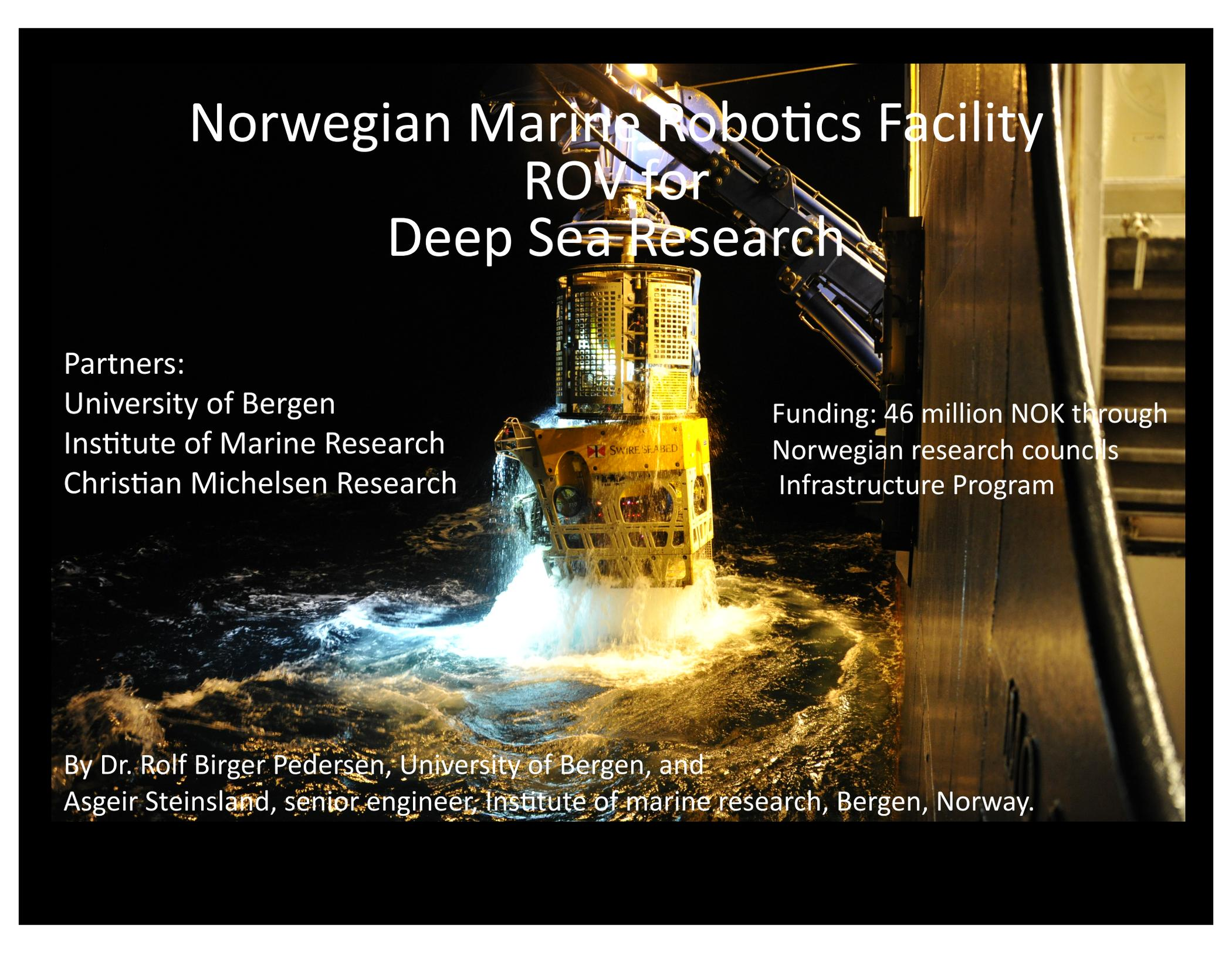

Norwegian Marine Robotics Facility ROV for Deep Sea Research

A yellow and white ROV (Remotely Operated Vehicle) is being lowered into the water by a crane. The ROV has a cylindrical body with a grid-like structure on top and a yellow base. It is surrounded by water splashing. The background is dark, suggesting a deep sea environment. The ROV has the text "SWIRE SEABED" on its side.

Partners:

University of Bergen

Institute of Marine Research

Christian Michelsen Research

Funding: 46 million NOK through
Norwegian research councils
Infrastructure Program

By Dr. Rolf Birger Pedersen, University of Bergen, and
Asgeir Steinsland, senior engineer, Institute of marine research, Bergen, Norway.

Kystdesign Supporter

Hydraulic work class ROV 4000m



Pay Load and Through Frame Lift Capacity



Pay Load	200Kg in water, with the following equipment mounted : Basic Skid, Schilling Atlas, Schilling T4, Sonar, Altimeter, Depth sensor, 7 Cameras, 1 SIT camera, 10 Lights, 2 P&T units, 1 Tilt unit
Through frame lift capacity	3000Kg

340 kg upward pull

Room For Scientific Payload on the Outside



Room for scientific Payload Inside the Structure

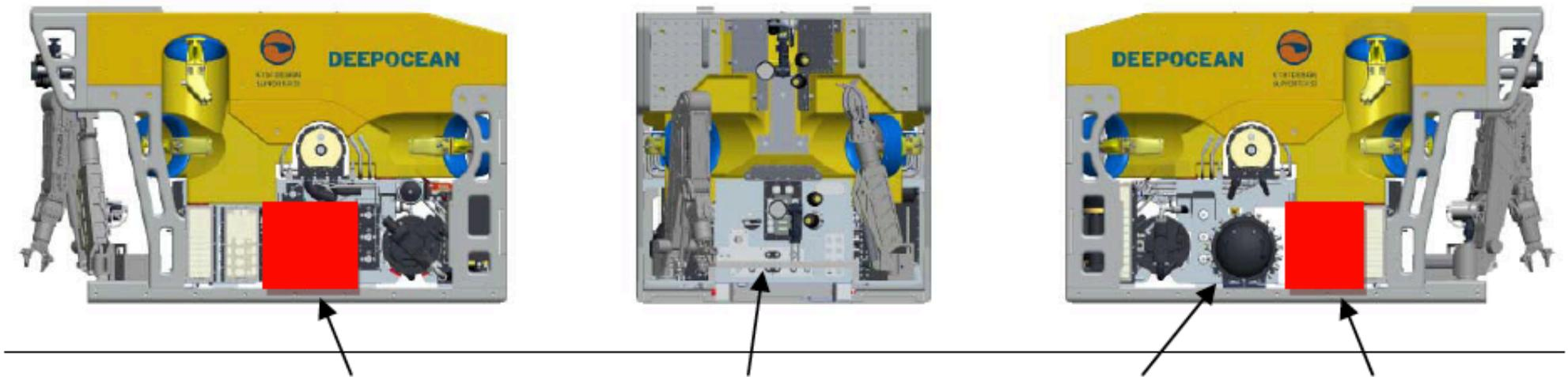

Camera systems

- 2x Sidus Pan & Tilt with position feedback, type SS109HT
- 2x HD-SDI 1080p on pan tilts
- 1x HD-SDI 1080p
- 1x Imenco Low Light, type Basking
- 2x Imenco Tool camera, type Greytip



Lighting

16 x 130W Dimable LED lights
210.000 Lumen



Sealite[®] Sphere

Highest Lumen per Weight and Lumen per Watt value in our LED Lineup.



FEATURES

- Easy Direct Replacement of a Halogen Light
- 6000 m (Standard) and 11000 m (Optional) Depth Rated
- Available in Different Colors and Color Temperatures
- Virtually Zero Maintenance
- Constant Current Drivers for Flicker-Free Operation
- Operates In or Out of Water
- Fully Dimmable

DEEPOCEAN
POWER & LIGHT



T: (858) 576-1261
F: (858) 576-0219

4033 Ruffin Road
San Diego, CA
92123- 1817 USA

www.deepsea.com
sales@deepsea.com



Skid & Drawers

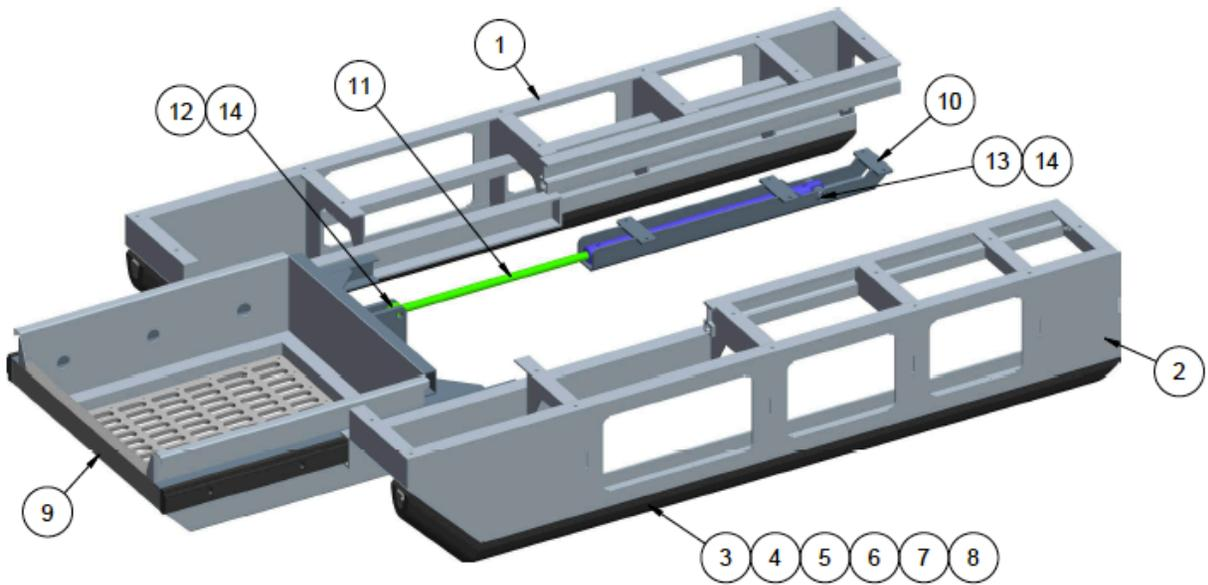
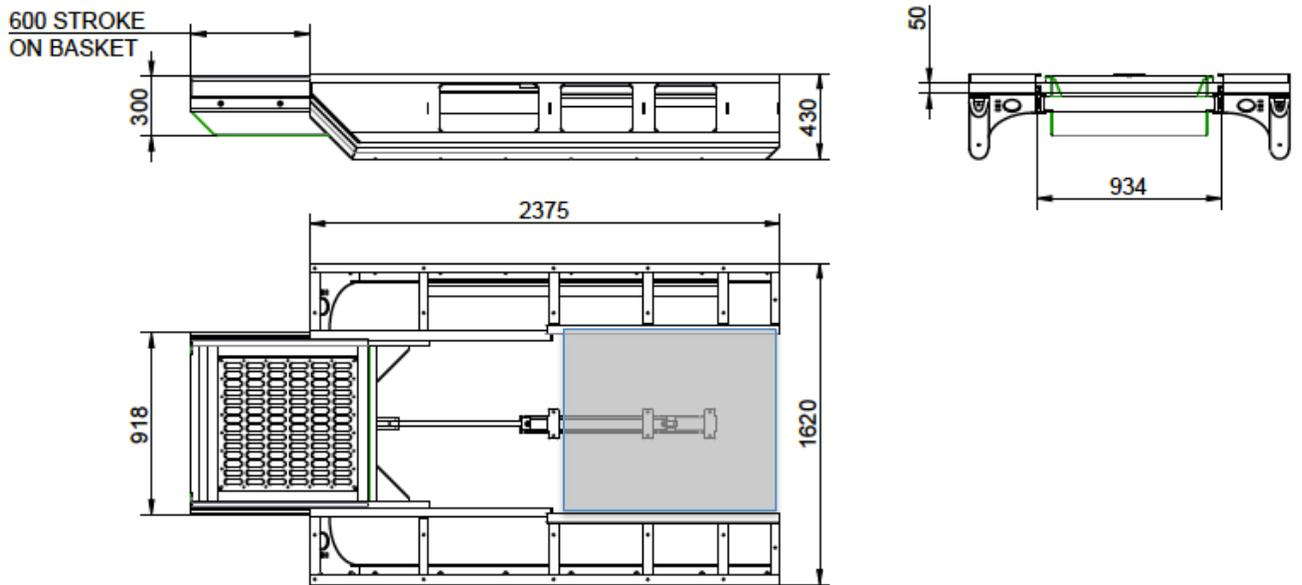

SCALE 7:100

Manipulators and toolskid

Schilling T4

Schilling Atlas

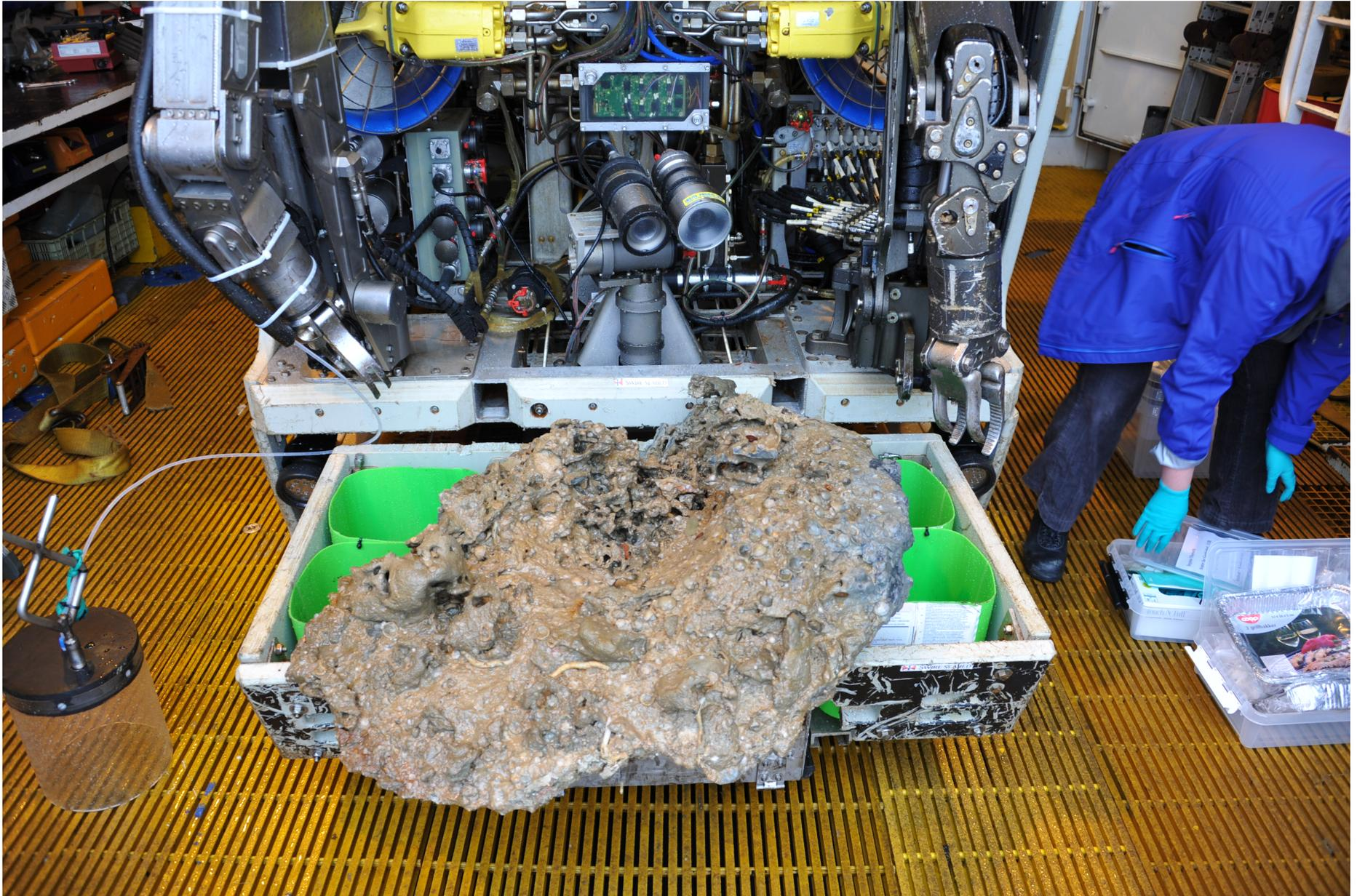

Hydraulic valves available for samplers and tooling

Two separate hydraulic system

- 1) Propulsion and arms
- 2) Auxiliary system for samplers and tools

Auxiliary system includes the following
proportional valves that are controlled
topside:

- 1) 11 x 8 l/min @200bar
- 2) 4 x 75 l/min @200bar
- 3) 1 x 200 l/min @200bar

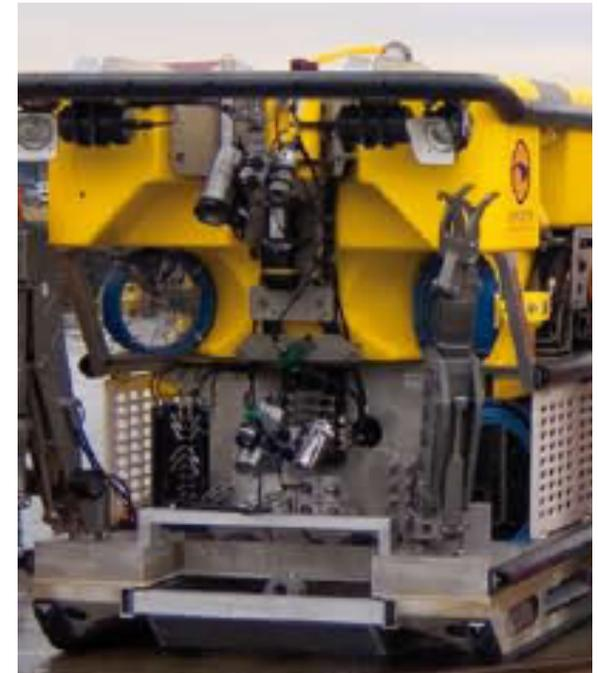

Survey Frame

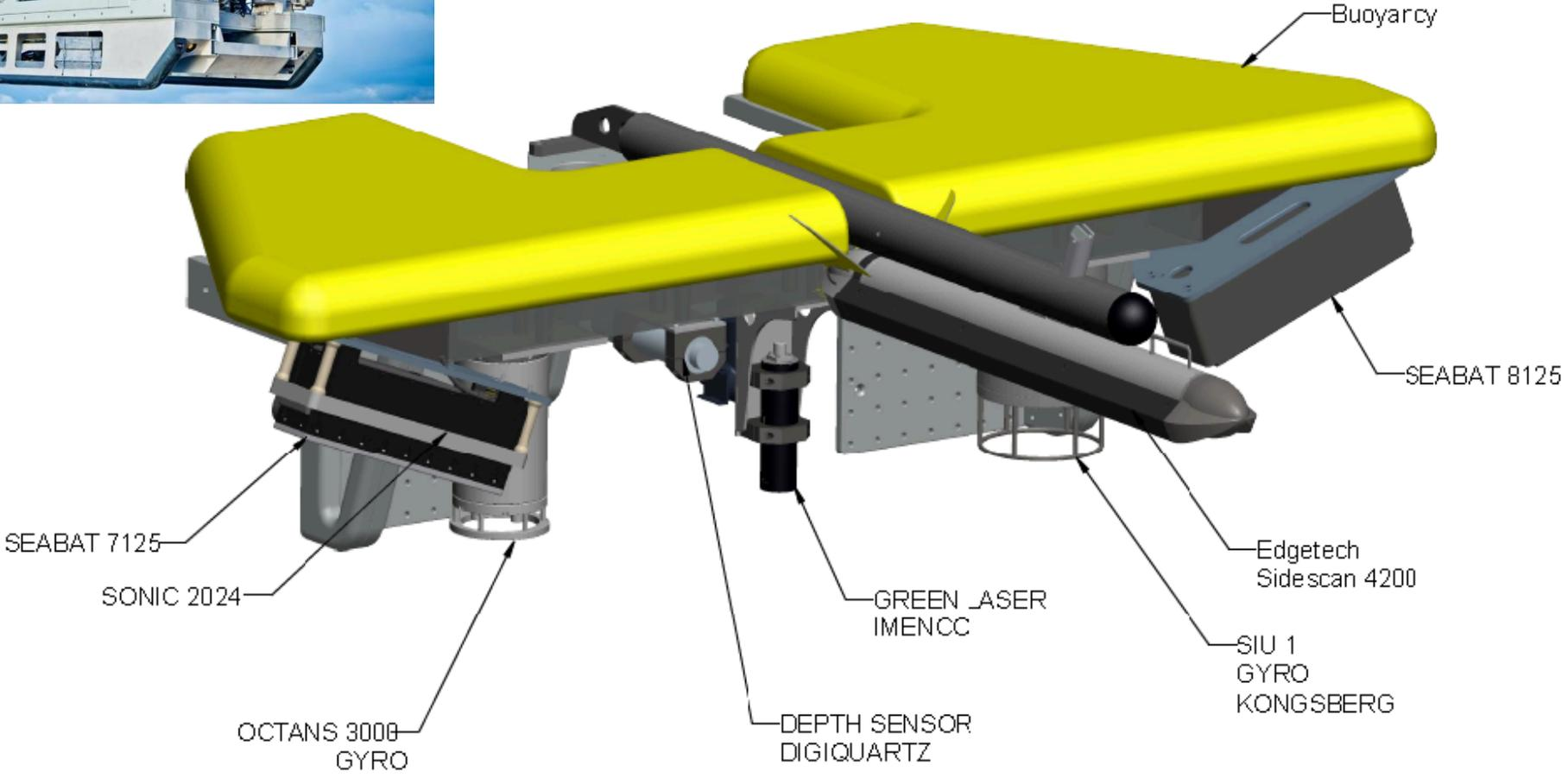

Navigation Sensors

Supplier	Description	Type	Qty
Ixblue	Inertial Platform, ROV INS		1
MacArtney	MS1171 4000m Dual freq. Sonar, Imaging P/N: 975-21030000 ,Incl.:MS1000 Software processor Express Version	35201312	1
	Doppler, NavQuest 600 Micro		1
Innova	PA500 Precision Altimeter	S02125 232	1
	Depth sensor 4000m		1
Kongsberg	Transponder MST 342/N - 4000m +/- 20°	MST-216277	2
MacArtney	ST-400A Novatech Xenon Flasher	31000110	1

Auto functions

- Auto heading
- Auto depth
- Auto altitude
- Auto position
- Auto track

Auto holding capability	Heading	+/- 1°
	Altitude	+/- 100 mm
	Depth	+/- 75 mm
Trim functions:	Pitch	+/- 10°
	Roll	+/- 10°

Power Supply and Telemetry for Sensors and Instruments

- 17 spare connections
- 5 spare optical fibers

Power supply for external sensors (default):

- 24Vdc
- 48Vdc
- 115 Vac

Telemetry system provides interfaces

- serial communication (RS232/485/TTL)
- Ethernet
- Other interfaces can be provided if needed

Samplers, sensors & Tools

- Water/gas samplers
 - high temp
 - low temp
- Suction sampler
- Biosyringe
- Push cores
- Chain saw
- Rock drill
- CO₂
- CH₄ (Methane)
- Temperature probes
- CTD

Our research vessels,
where the ROV will be used.



Installation of ROV and LARS on R/V G.O. Sars

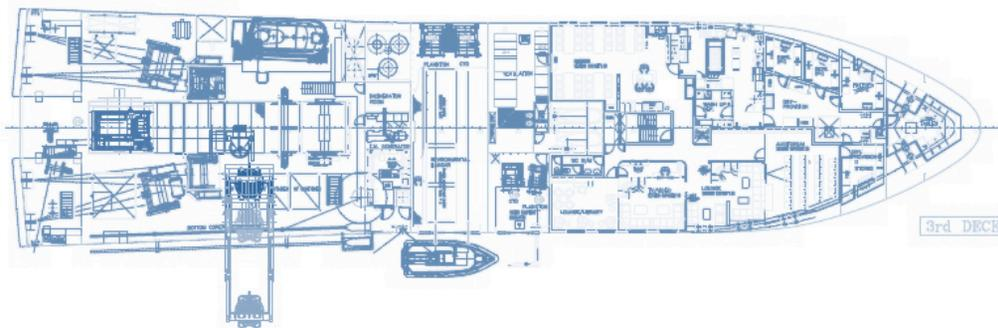
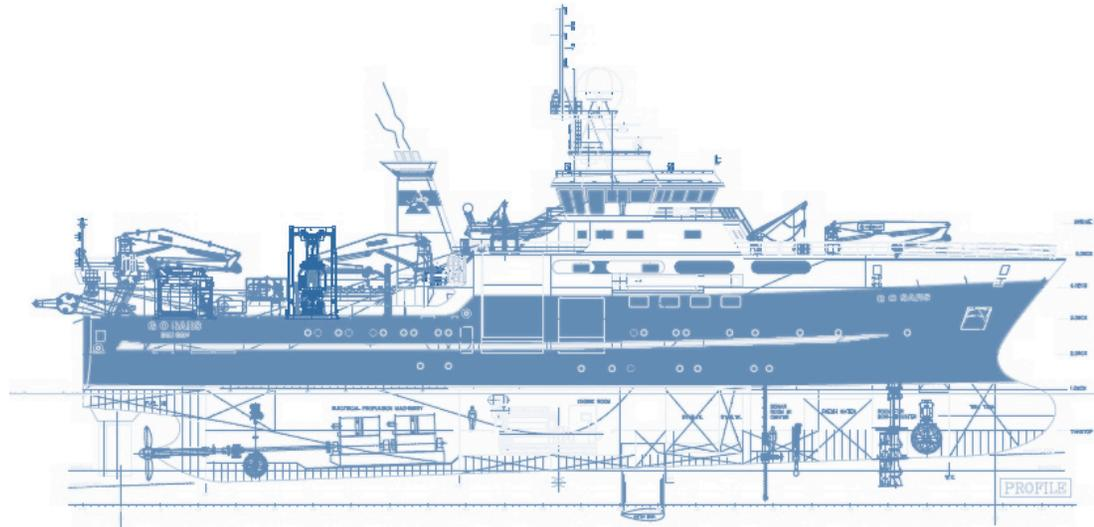

Full installation with TMS and AHC winch

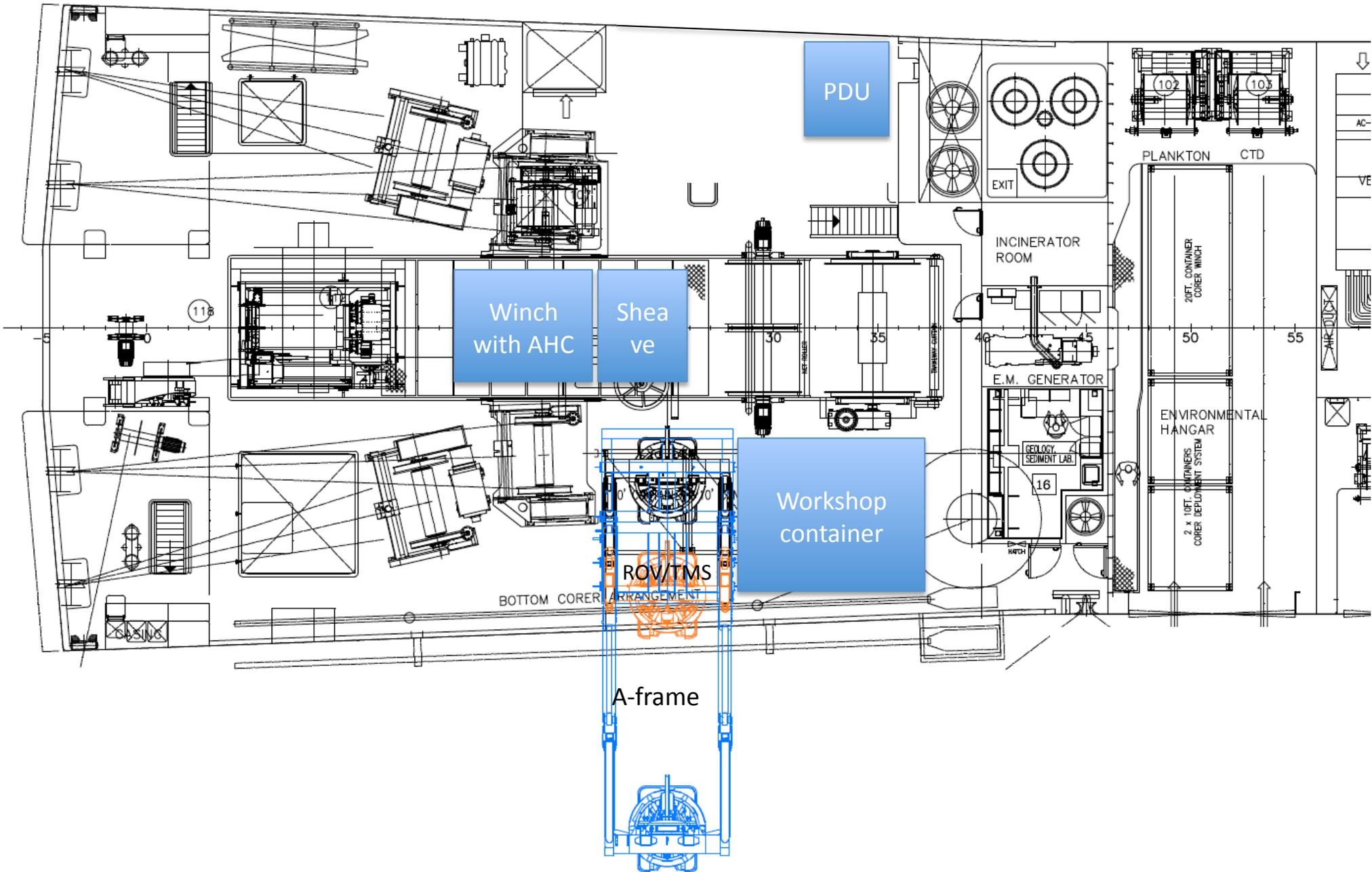

Launch and Recovery System (LARS) SEPRO





Minimum Installation in the hangar Without TMS.

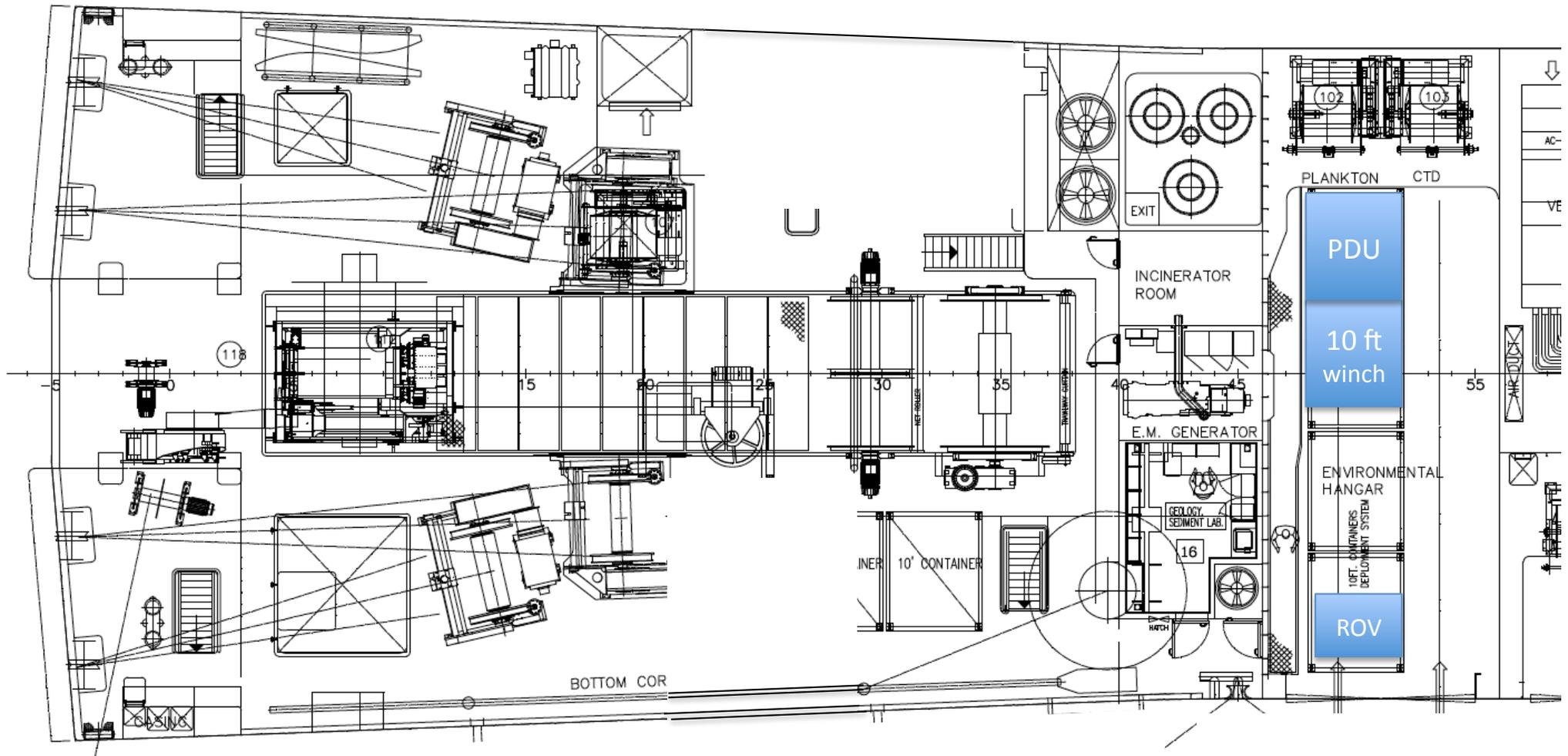

Installation - Hangar

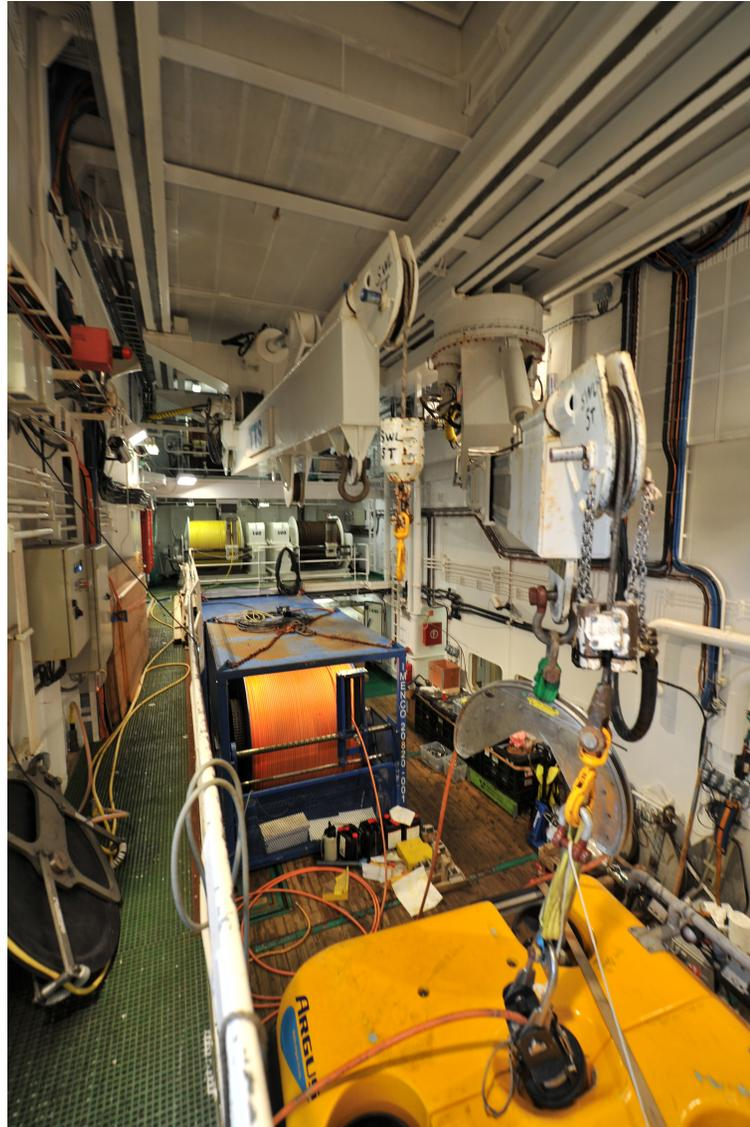

ROV Control room

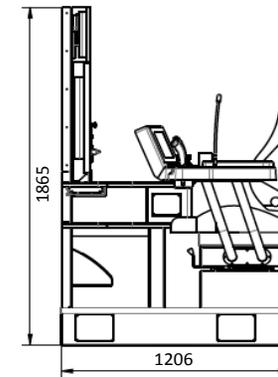
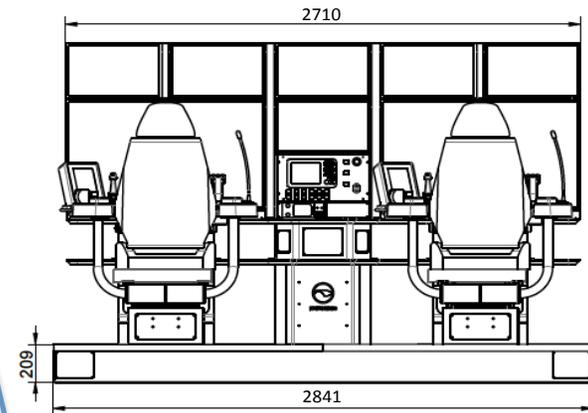
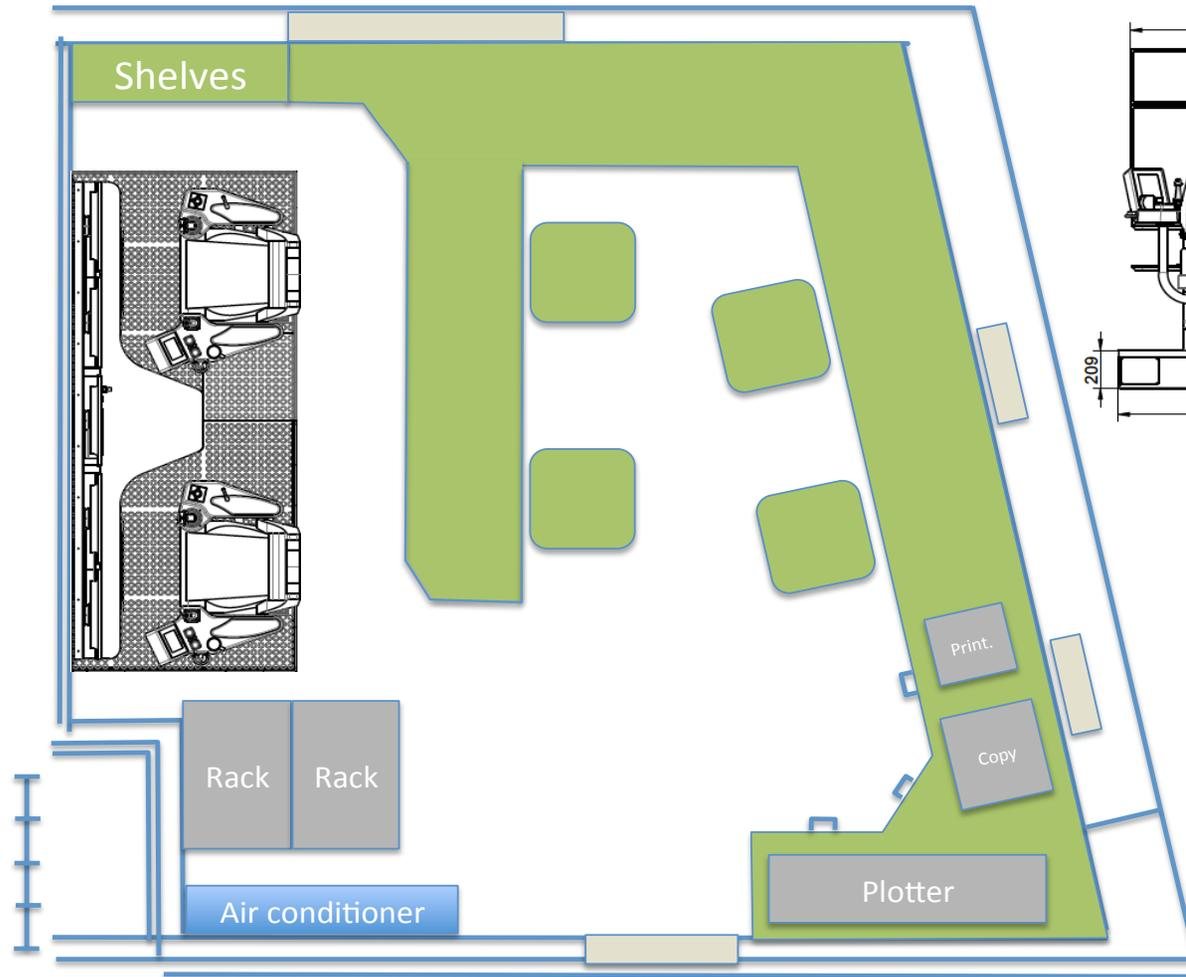

1 m

