

REVISIONS BAY MARINE, INC.			
<small>215-006-001</small> <small>215 NEW MEADOW ROAD</small> <small>BARRINGTON, RI 02803</small> <small>(401) 245-6910</small>			
NSF / ONR LOAD HANDLING SYSTEM STUDY AFT DECK ARRANGMENT			
SCALE:	AS NOTED	DATE:	2/24/2016
DWG. NO.:	C215-003	BY:	JRS
		REV:	—

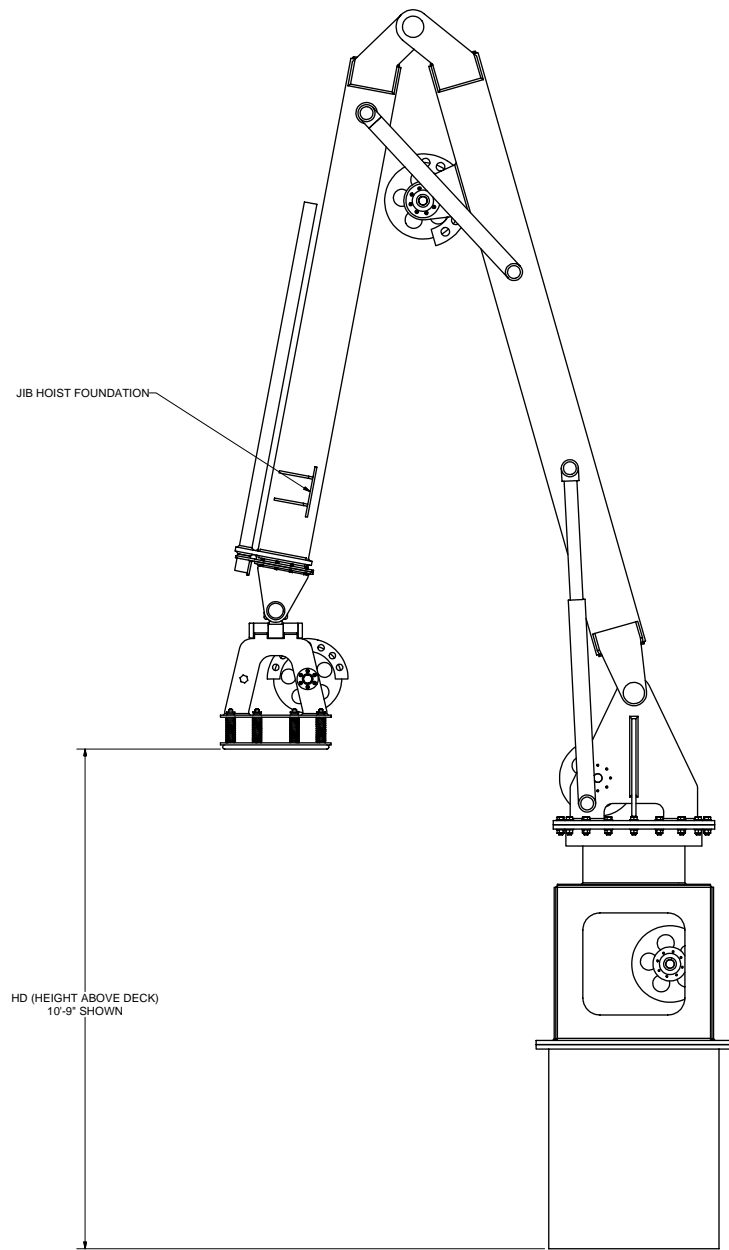

FULLY RETRACTED
PROFILE VIEW - SCALE: 3/4"=1'-0"

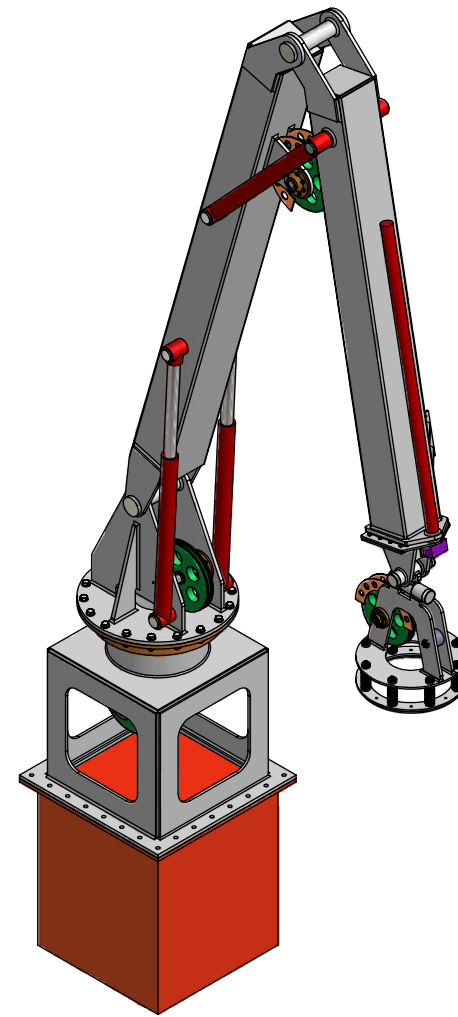
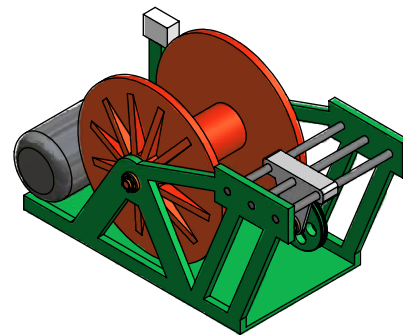

FULLY RETRACTED
ISOMETRIC VIEW - SCALE: 3/4"=1'-0"



REVISIONS
BAY MARINE, INC.

NSF / ONR
LOAD HANDLING SYSTEM STUDY
AFT DECK ARRANGMENT

THIS DOCUMENT CONTAINS INFORMATION PROPRIETARY TO BAY MARINE, INC. UNLESS THE DOCUMENT AND ITS CONTENTS ARE TO BE REPRODUCED, COPIED, OR USED IN ANY WAY, IN WHOLE OR IN PART, EXCEPT AS EXPRESSLY AUTHORIZED IN WRITING BY BAY MARINE, INC.

SCALE: AS NOTED	DATE: 2/24/2015	BY: JES
DWG. NO.: 0215-003		REV: —