

Troubleshooting RDI Vessel Mounted ADCPs

What can go wrong with workhorse or ocean surveyor vessel-mounted instrument and how to troubleshoot it. This breakout is at the instrument level, not SOP for operations.

Use and Disclosure of Data Information contained herein is classified as EAR99 under the U.S. Export Administration Regulations. Export, reexport or diversion contrary to U.S. law is prohibited.

Teledyne RDI

Founded in 1982, acquired by Teledyne in 2005

Employees: 100+

Acoustic Doppler Current Profilers (ADCPs)

Doppler Velocity Logs (DVLs)

~50,000 ADCPs/DVLs sold





TELEDYNE MARINE
Everywhereyoulook™

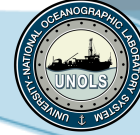
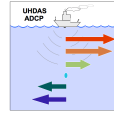

Vessel Mounted ADCPs

Acoustic Doppler Current Profilers for Ocean Applications

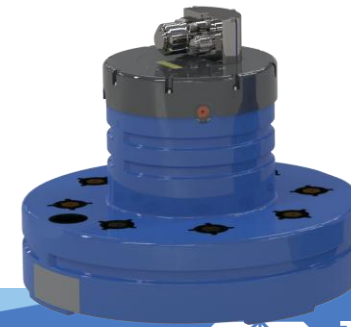
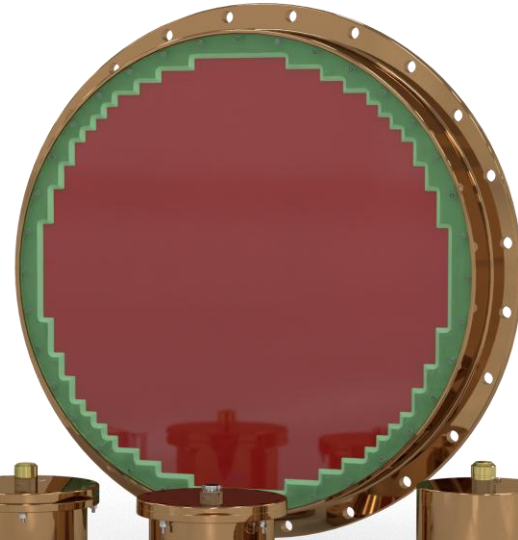
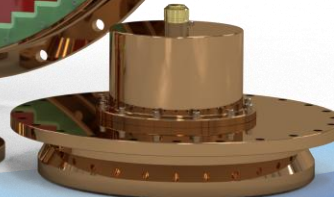
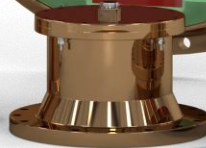

General Outline

- Types of errors
 - Acoustic
 - Mechanical
 - Electrical
- Ocean Surveyor
 - ADCP design where errors can get in
 - Diagnosing Failures
- Workhorse
 - ADCP design where errors can get in
 - Diagnosing Failures
- Contacting RDIFS
- New UHDAS SOP for Ocean Surveyors

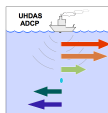

Types of errors

- Acoustic
 - Other sonars
 - Environmental data
- Mechanical
 - Bubbles
 - Ringing
 - Transducer failure
- Electrical
 - See below

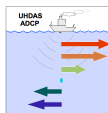

Types of errors - Acoustic

- Other sonars
- Environmental data

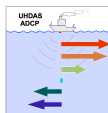
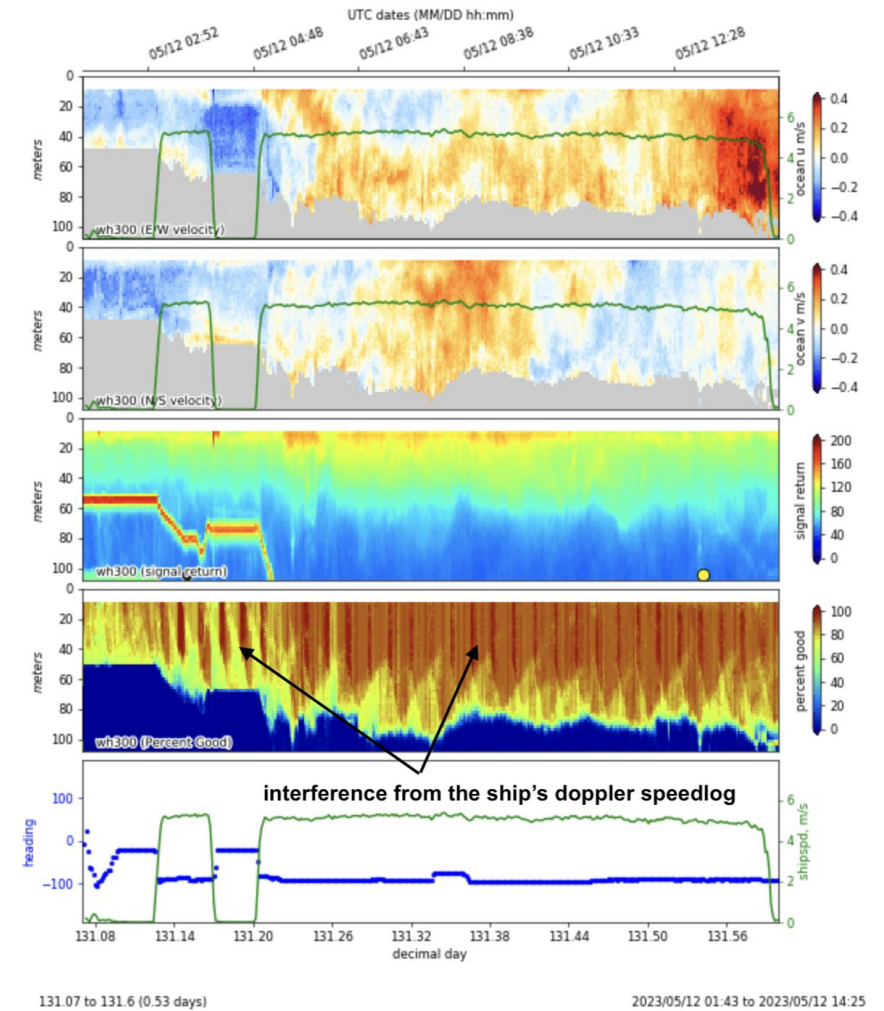
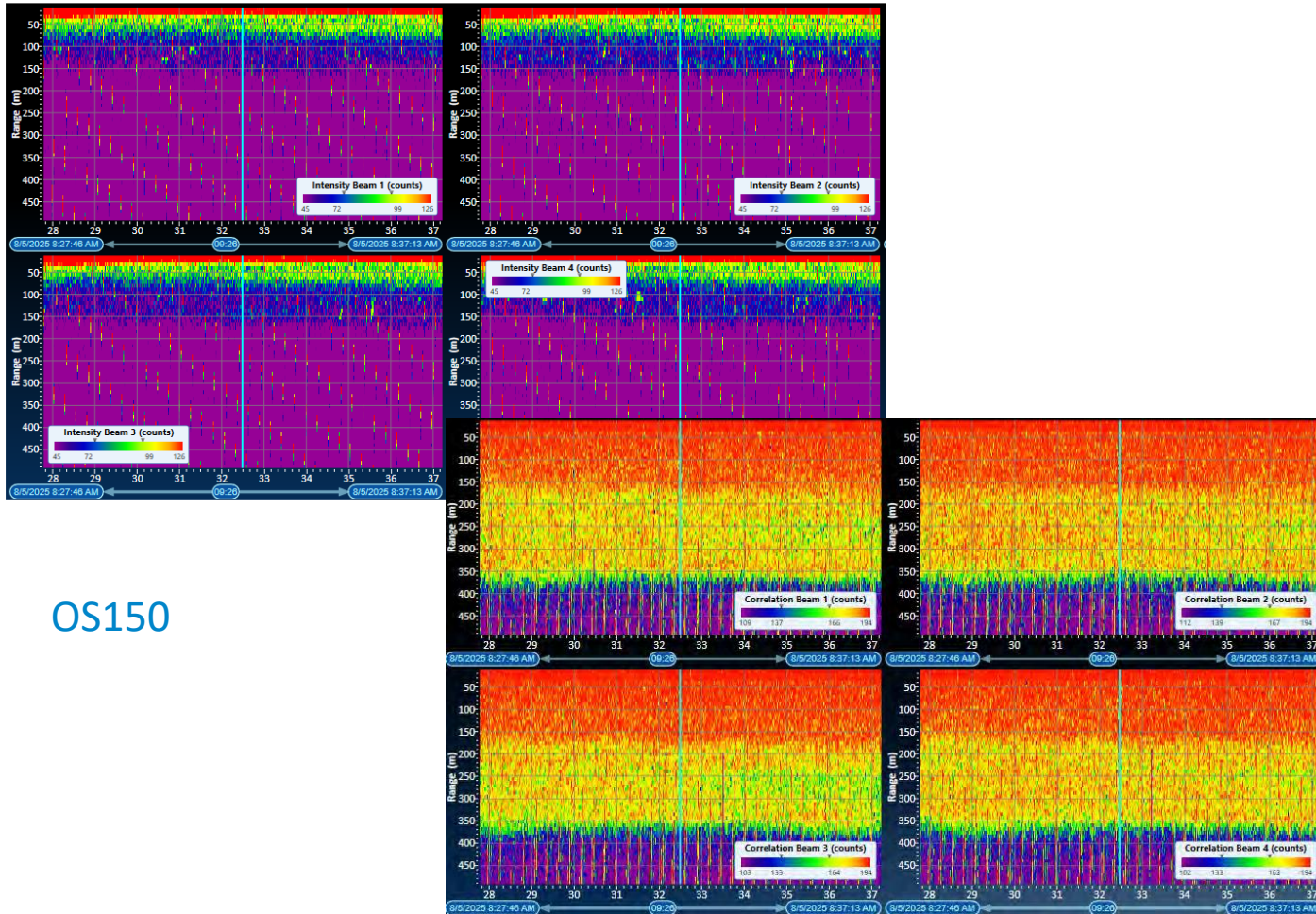

Types of errors - Acoustic

- Other sonars
- Environmental data
 - Waves & storms
 - Lack of scattering material
 - Decreased range

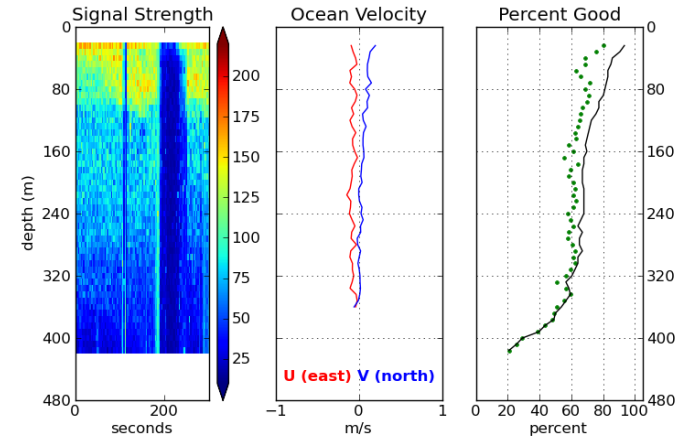

nb150
heading correction: -0.12 deg, 2008/01/26 20:09:43 UTC

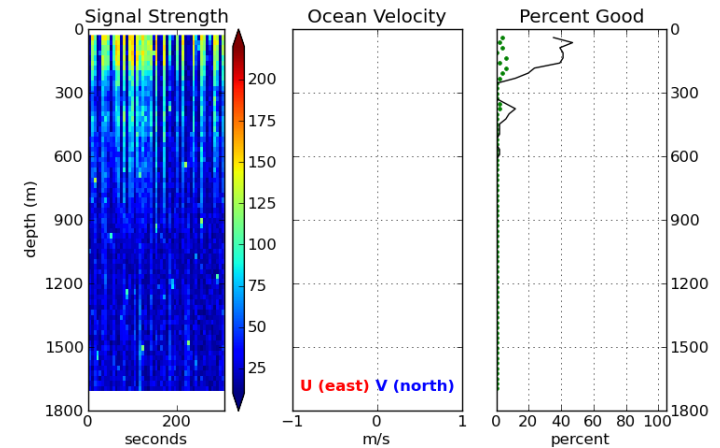

os38nb
heading correction: 2.59 deg, 2008/06/03 05:43:17 UTC

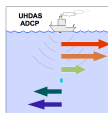
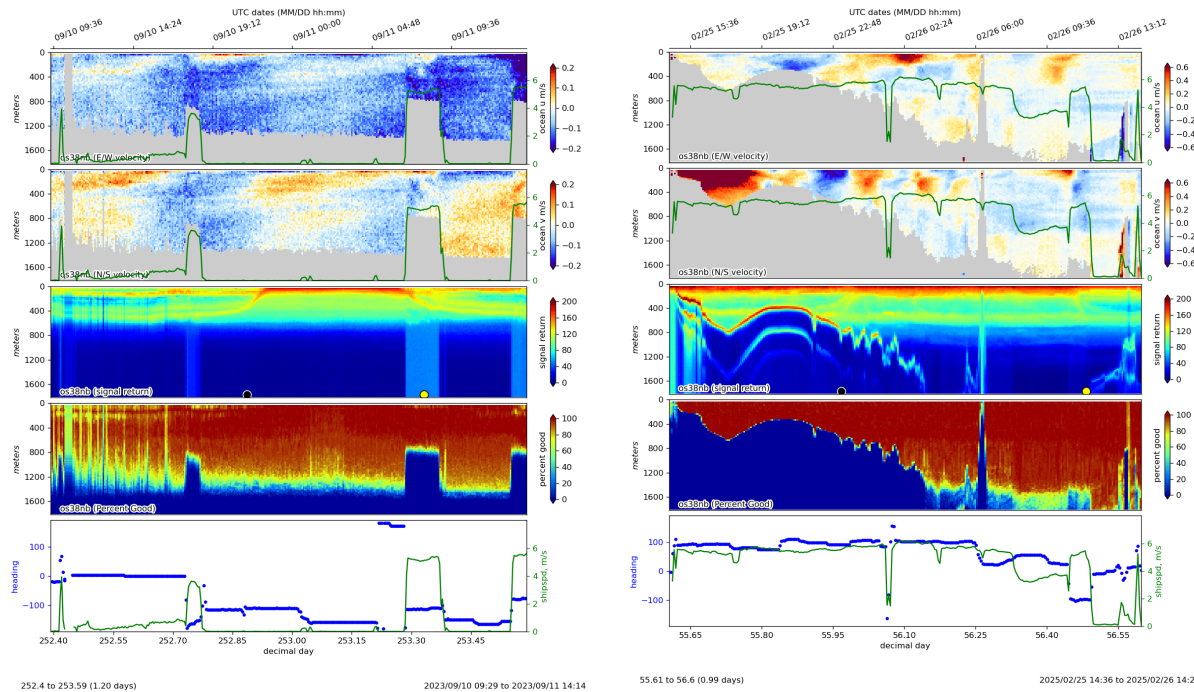

Types of errors - Mechanical

- Mechanical
 - Bubbles
 - Ringing
 - Well design
 - Dampening material
 - Lack of isolation
 - Use higher frequency ADCP
 - Change Blanking Distance
- Transducer failure

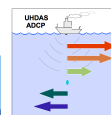
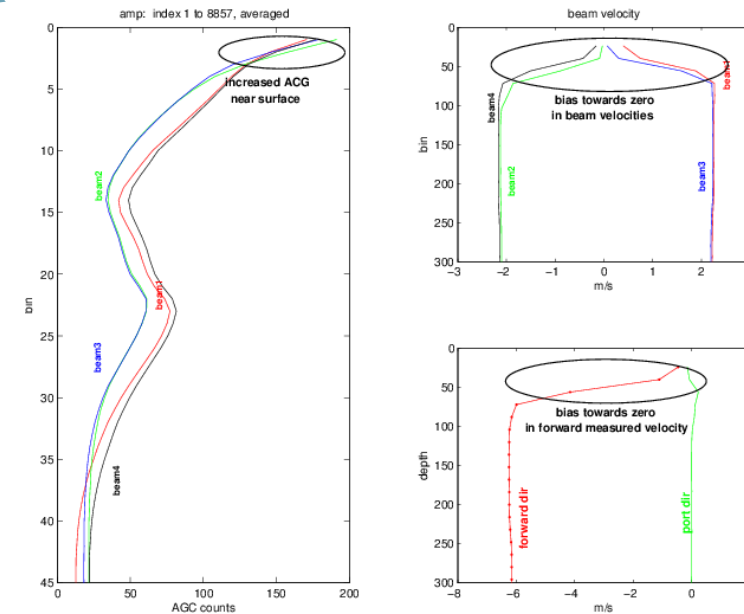
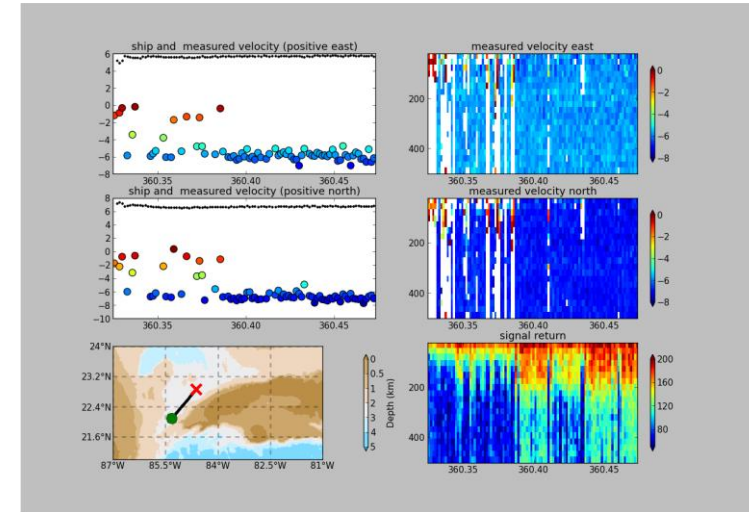

Types of errors - Electrical

- EMF generators near the deck unit
 - Eg. Knudsen, CRT monitor
- EMF near Ocean Surveyor cable
 - other power lines
 - other transducers cables
- WH300 bad power supply

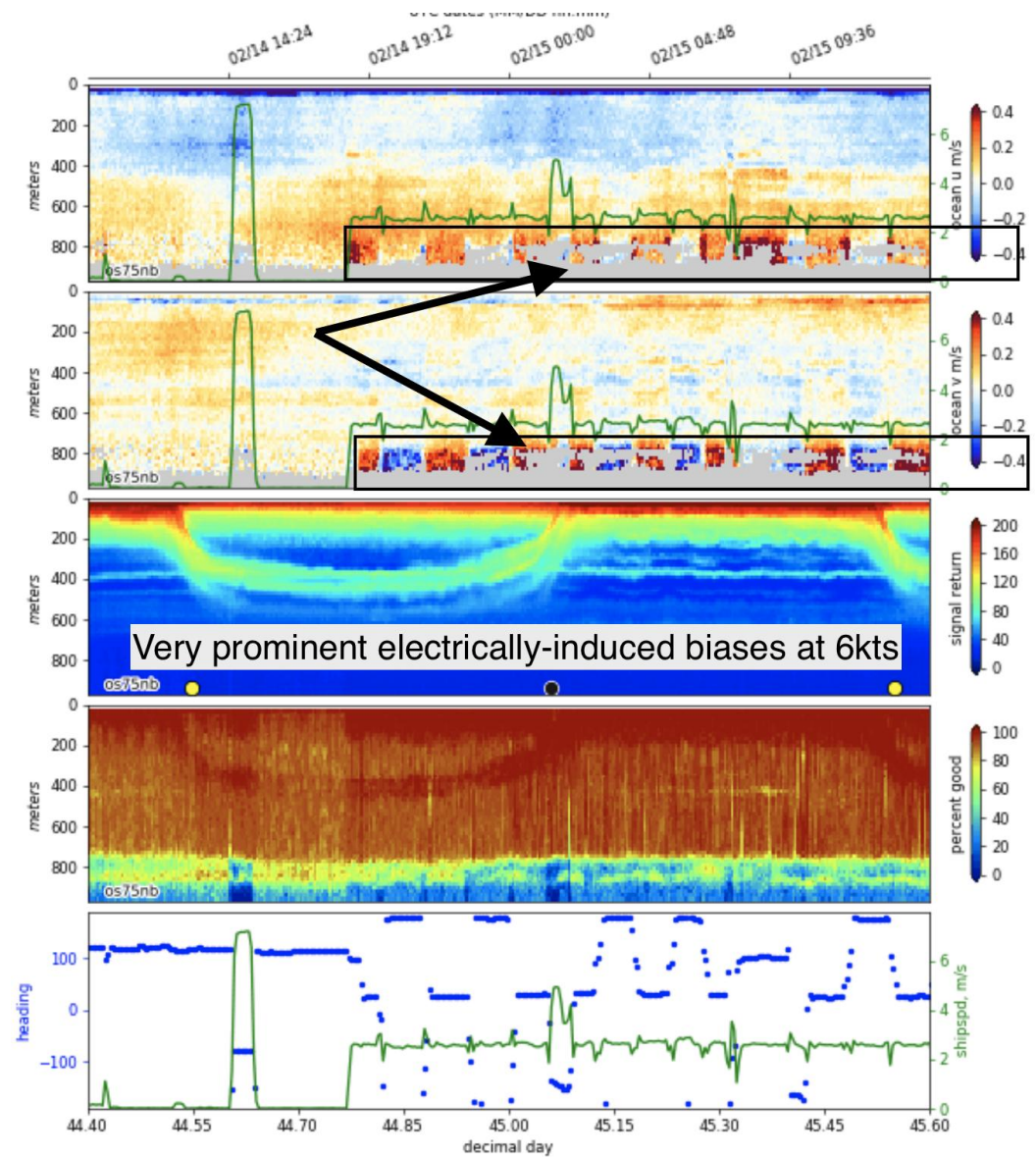

44.4 to 45.6 (1.20 days)

2021/02/14 09:42 to 2021/02/15 14:27

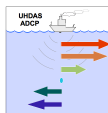

• Ocean Surveyor

- ADCP design where errors can get in
- Diagnosing Failures

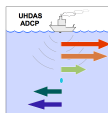

ADCP design where errors can get in -OS

- Ocean Surveyor
 - Transducer
 - **Urethane Coating**
 - Inside Transducer
 - Ceramic Array
 - Beamformer Board
 - Thermistor
 - Bulkhead Connector
 - No O-ring
 - Analog Cable
 - Wet Side
 - Dry Side
 - RS-232 vs 422
 - signal processing in deck unit
 - deck unit is power + comms



ADCP design where errors can get in -OS

- Ocean Surveyor
 - Transducer
 - Urethane Coating
 - Inside Transducer
 - **Ceramic Array**
 - Beamformer Board
 - Thermistor
 - Bulkhead Connector
 - No O-ring
 - Analog Cable
 - Wet Side
 - Dry Side
 - RS-232 vs 422
 - signal processing in deck unit
 - deck unit is power + comms

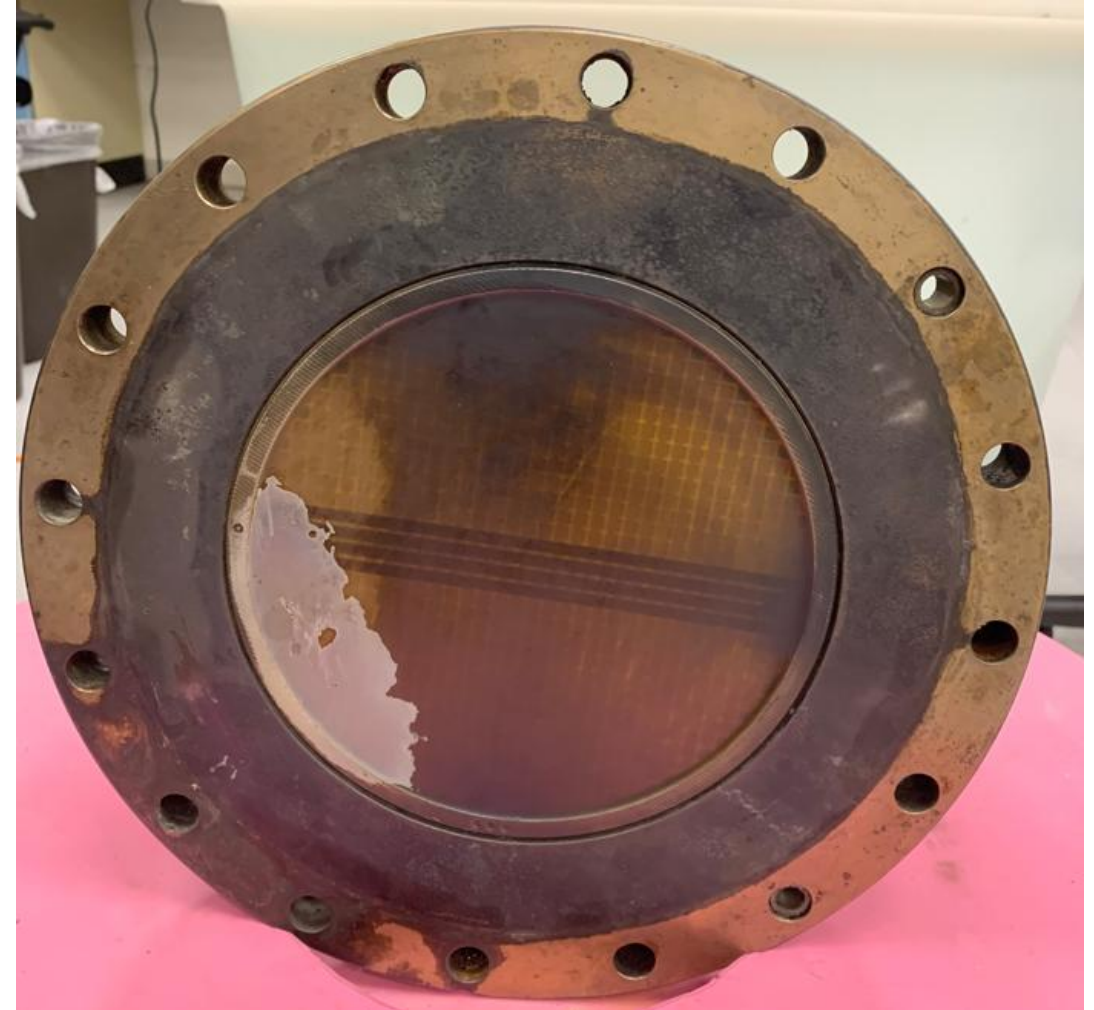

ADCP design where errors can get in -OS

- Ocean Surveyor
 - Transducer
 - Urethane Coating
 - Inside Transducer
 - Ceramic Array
 - **Beamformer Board**
 - Thermistor

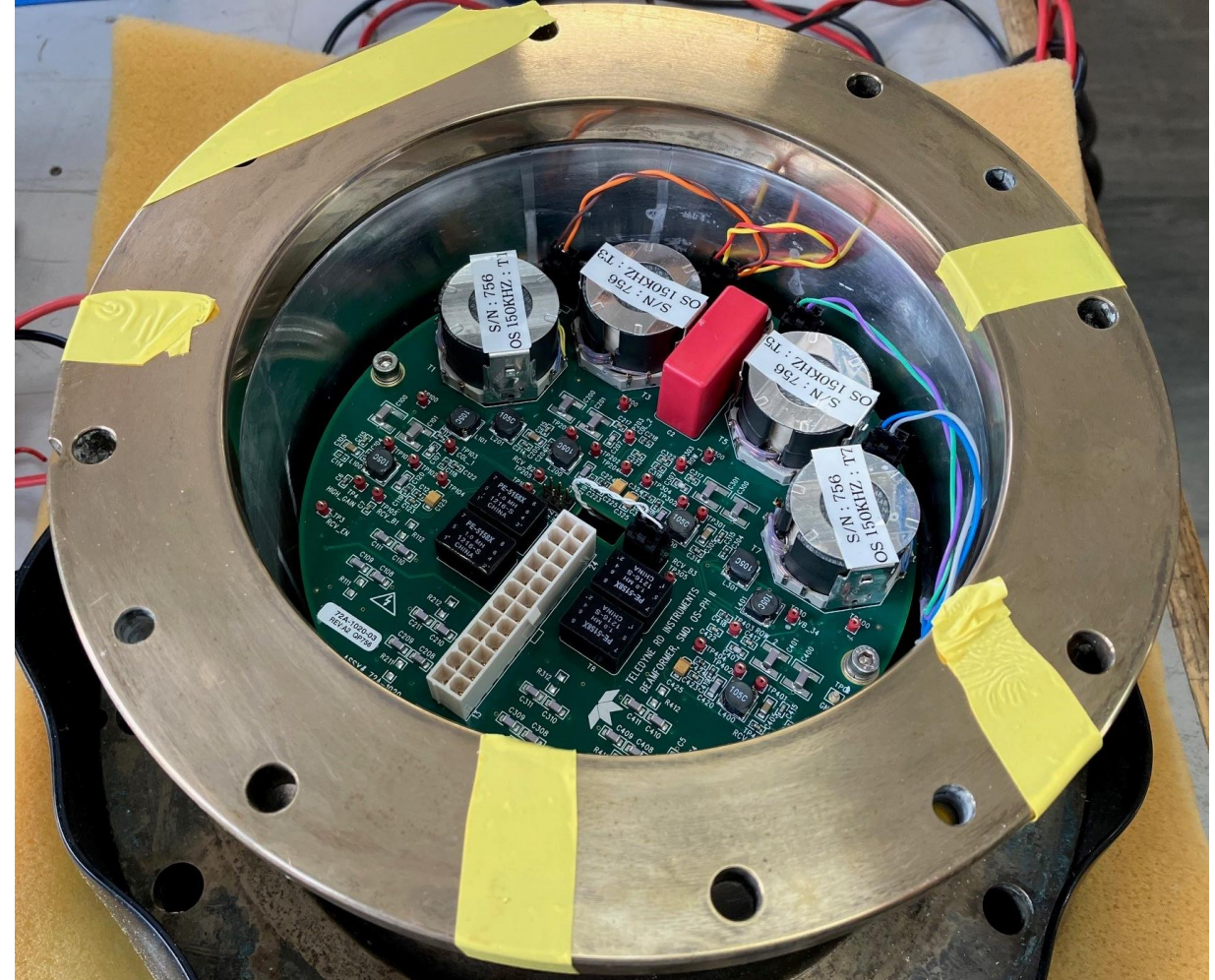

ADCP design where errors can get in -OS

- Ocean Surveyor
 - Transducer
 - Urethane Coating
 - Inside Transducer
 - Ceramic Array
 - Beamformer Board
 - **Thermistor**

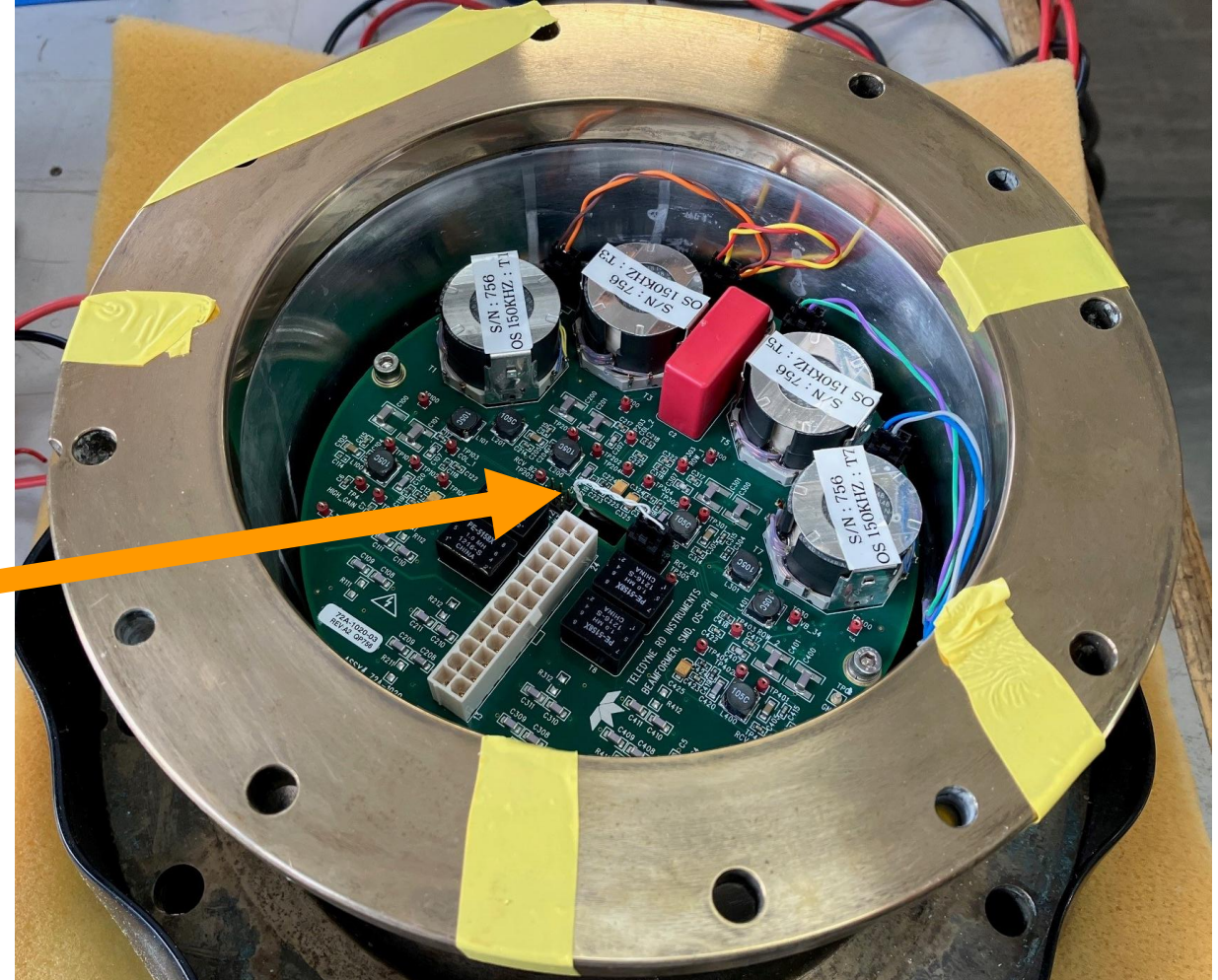

ADCP design where errors can get in -OS

- Ocean Surveyor
 - Bulkhead Connector
 - No O-ring
 - Cable O-ring: 2-022, DURO 70, EPDM
 - Bulkhead Connector O-ring: 2-020, DURO 70, EPDM

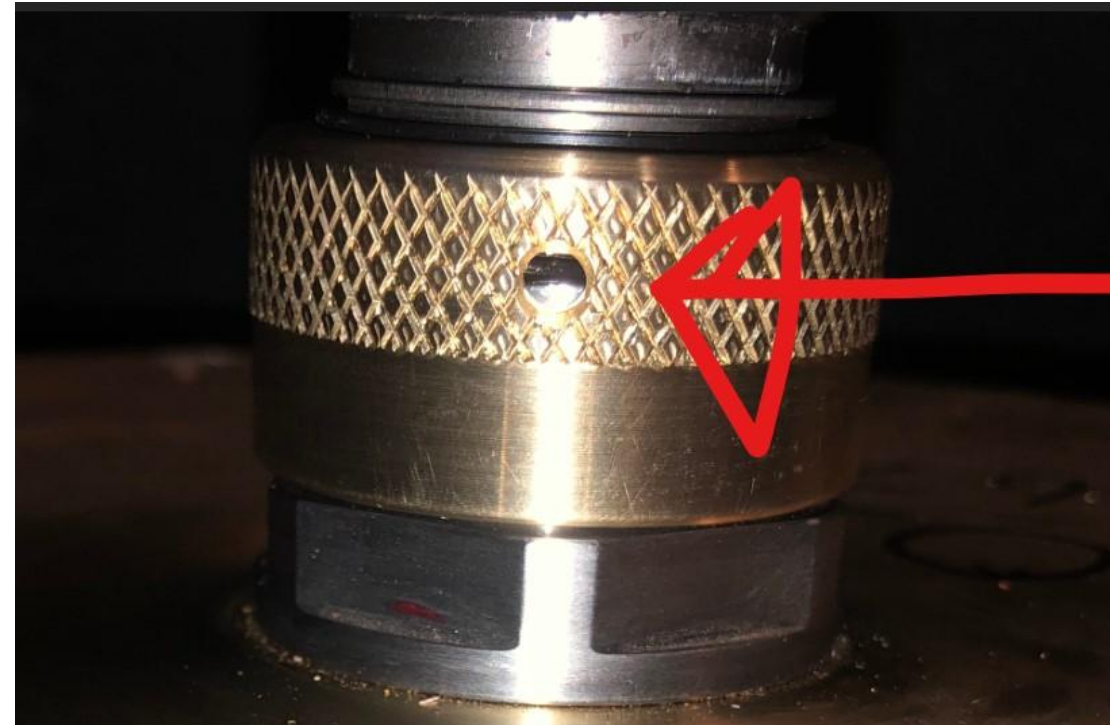
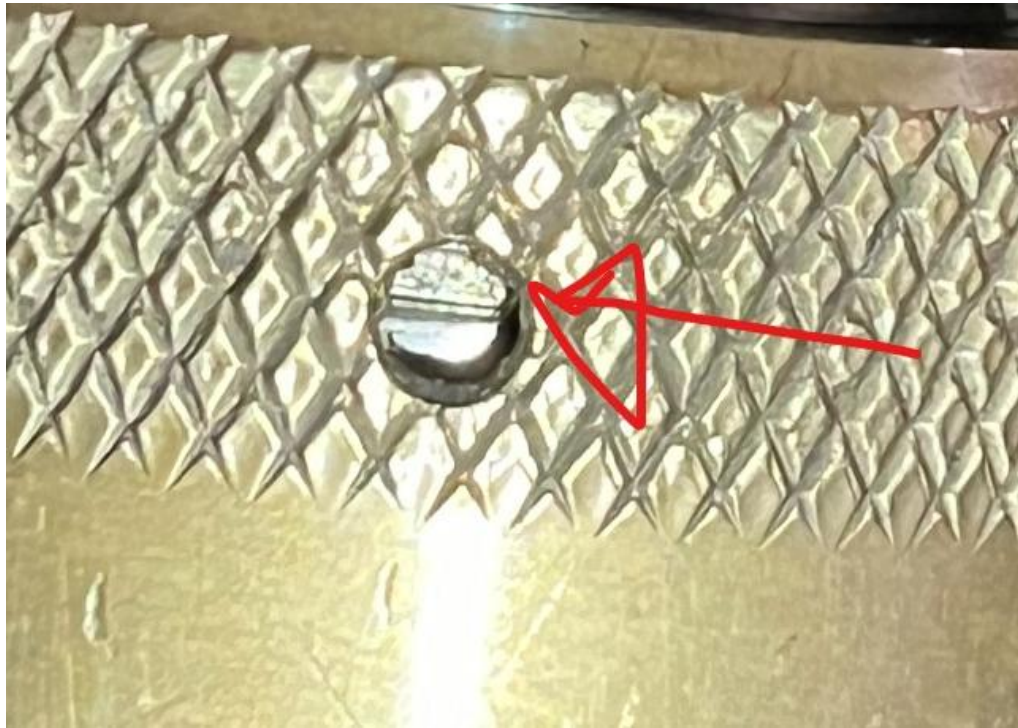

Diagnosing Failures – Ocean Surveyor

- Fault log commands
 - LD – Displays Fault Log
 - LL – Displays possible fault list
 - LC – Clears Fault Log
- Running the PT tests
 - PT0 - Displays system information
 - PT3 – Receive path test
 - Expecting to see RSSI ~ 50 counts
 - PT6 – Receive bandwidth test
 - PT5 – Electronics wrap around test (**DO NOT PERFORM THIS TEST OUT OF WATER**)
- Cable resistance checks
- When to "disconnect the deck unit and run the PT tests again"
- FFT
- Data Review (https://currents.soest.hawaii.edu/uhdas_dot_org/bad_beams/index.html)

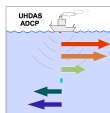

Diagnosing Failures – Ocean Surveyor

- Fault log commands
 - LD – Displays Fault Log
 - LL – Displays possible fault list
 - LC – Clears Fault Log

To determine why a sensor failed, view the fault log. To view the fault log, start *TRDI Toolz*. Press the **End** key to wake up the ADCP. Send the following commands: **CR1**, **PC2**, **LD**. The LD-command displays the fault log.

```
[BREAK Wakeup A]

Ocean Surveyor Broadband/Narrowband ADCP
TELEDYNE RD INSTRUMENTS (c) 1997-2000
ALL RIGHTS RESERVED
Firmware Version 23.xx
>
>CR1
>PC2
|          (PC2 test results (not shown))
|
>LD
Time of first fault:   2000/08/23,10:08:13
Overflow count:       0

Fault Log:
  Code      Count      Time      Parameter
506  TEMP RANGE      3      2000/08/23,10:08:22  FFFF1D7h
203    RTC CAL      2      2000/08/23,10:08:19  00000001h

End of fault log.
```

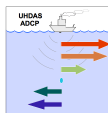

Diagnosing Failures – Ocean Surveyor

- Running the PT tests
 - PT0 - Displays system information
 - PT3 – Receive path test
 - Expecting to see RSSI ~ 50 counts
 - PT6 – Receive bandwidth test
 - PT5 – Electronics wrap around test
 - **(DO NOT PERFORM THIS TEST OUT OF WATER)**

```
>pt200
Correlation Magnitude:
.....
Lag   Bm1   Bm2   Bm3   Bm4
0     1.00  1.00  1.00  1.00
1     0.84  0.90  0.86  0.83
2     0.49  0.71  0.56  0.47
3     0.22  0.54  0.33  0.18
4     0.10  0.45  0.22  0.06
5     0.06  0.42  0.19  0.04
6     0.07  0.42  0.19  0.06
7     0.08  0.42  0.19  0.08

RSSI: 63 66 54 54

PASSED
Receive Bandwidth:
.....
Expected   Bm1   Bm2   Bm3   Bm4
-----
15500     13711 10138 12352 14609

FAILED:  Bm2  10138 < 12400
FAILED:  Bm3  12352 < 12400
```

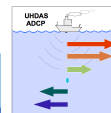

Diagnosing Failures – Ocean Surveyor

- Cable resistance tests
 - Dry side
 - Wet side
 - Bulkhead connector
 - End to End
 - Keep old data for comparison
- **Souriau 8500-1758A 900 Circular MIL Spec Contacts**
 - 1 mm male pins

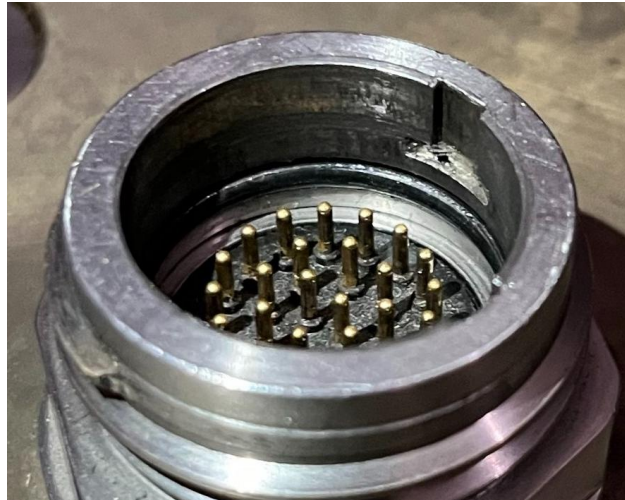

Multimeter recommendations



- When measuring resistance in phased array transducers, it's important to understand how multimeters interpret high resistance values:
- Resistance > 2 MΩ: Many multimeters will display “OPEN” or “OL” (Overload).
 - In most cases, this is not a fault—it’s typically considered a pass, but the exact reading is unknown.
- TRDI Recommended Equipment: Use a multimeter capable of measuring up to 20 MΩ.
- Personal Recommendation:
 - Fluke 115 and Fluke 117 models
 - These offer a range/resolution of 40.00 MΩ / 0.01 MΩ, which is more than adequate for accurate resistance checks in phased array systems.

Transducer Dry Connector Resistance Check

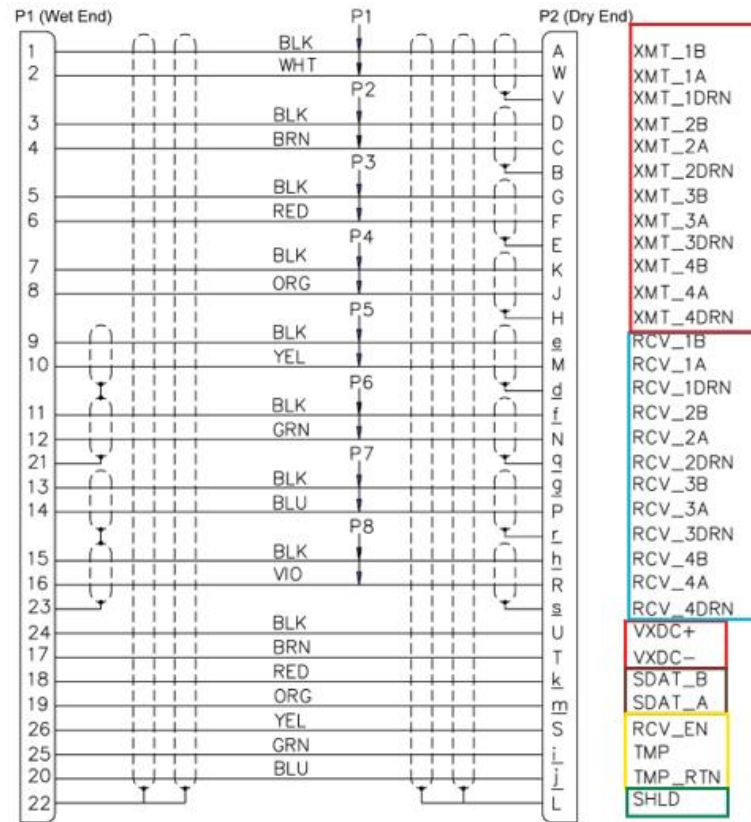
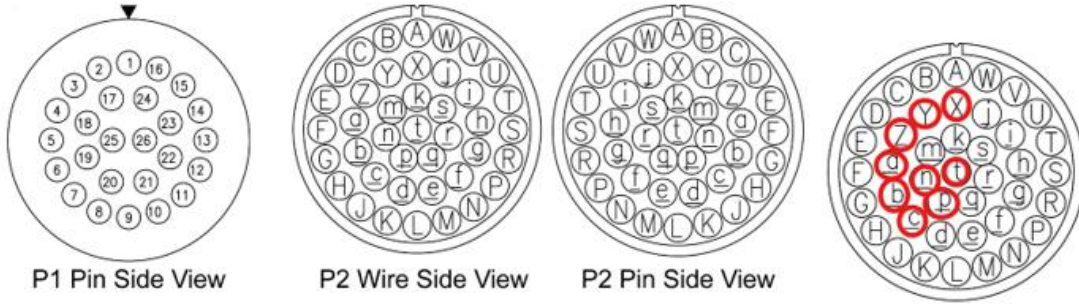

- When working with a phased array transducer, it's important to recognize that the beams operate as reciprocal pairs. This means that the resistance readings observed on both the transducer and the receiver board should generally mirror each other.
- A mismatch in resistance readings is typically a strong indicator of potential issues such as:
 - Component failure
 - Corrosion
 - System failure

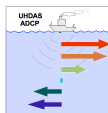

Transducer Dry Connector Resistance Check

Table 24: Transducer Dry Connector Resistance Check

Description	Cable Dry Connector		Resistance
	From	To	
BEAM 1 XMIT to XMIT RTN (see note 8)	A	W	> 1.5 Mohms
BEAM 2 XMIT to XMIT RTN (see note 8)	D	C	> 1.5 Mohms
BEAM 3 XMIT to XMIT RTN (see note 8)	G	F	> 1.5 Mohms
BEAM 4 XMIT to XMIT RTN (see note 8)	K	J	> 1.5 Mohms
BEAM 1 RCV HI to BEAM 1 RCV LOW (see note 10)	e	M	< 15 ohms
BEAM 2 RCV HI to BEAM 2 RCV LOW (see note 10)	f	N	< 15 ohms
BEAM 3 RCV HI to BEAM 3 RCV LOW (see note 10)	g	P	< 15 ohms
BEAM 4 RCV HI to BEAM 4 RCV LOW (see note 10)	h	R	< 15 ohms
SHIELD to SHIELD	d	q	< 5 ohms
SHIELD to SHIELD	r	s	< 5 ohms
SHIELD to SHIELD	d	r	> 20 Mohms
RCV ENABLE to VXDC GND (see note 9)	S	T	4.75 or 99 kohms
TEMP to TEMP RTN	i	j	11.3 kohms
VXDC to VXDC GND (see note 6)	U	T	Diode Check Reverse Bias Forward Bias
SDAT B to VXDC GND (see note 7)	k	T	5.9 kohms
SDAT A to VXDC GND (see note 7)	m	T	> 20 Mohms
SHIELD to ALL	B	ALL	> 20 Mohms
SHIELD to ALL	E	ALL	> 20 Mohms
SHIELD to ALL	H	ALL	> 20 Mohms
SHIELD to ALL	V	ALL	> 20 Mohms

Transmit

Receive

Receive twisted pair shielding

Beamformer board (Diode Check)

Temperature Sensor

Power

Synchro (typically not used)

Transmit twisted pair shielding

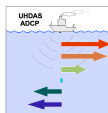

OS Cable

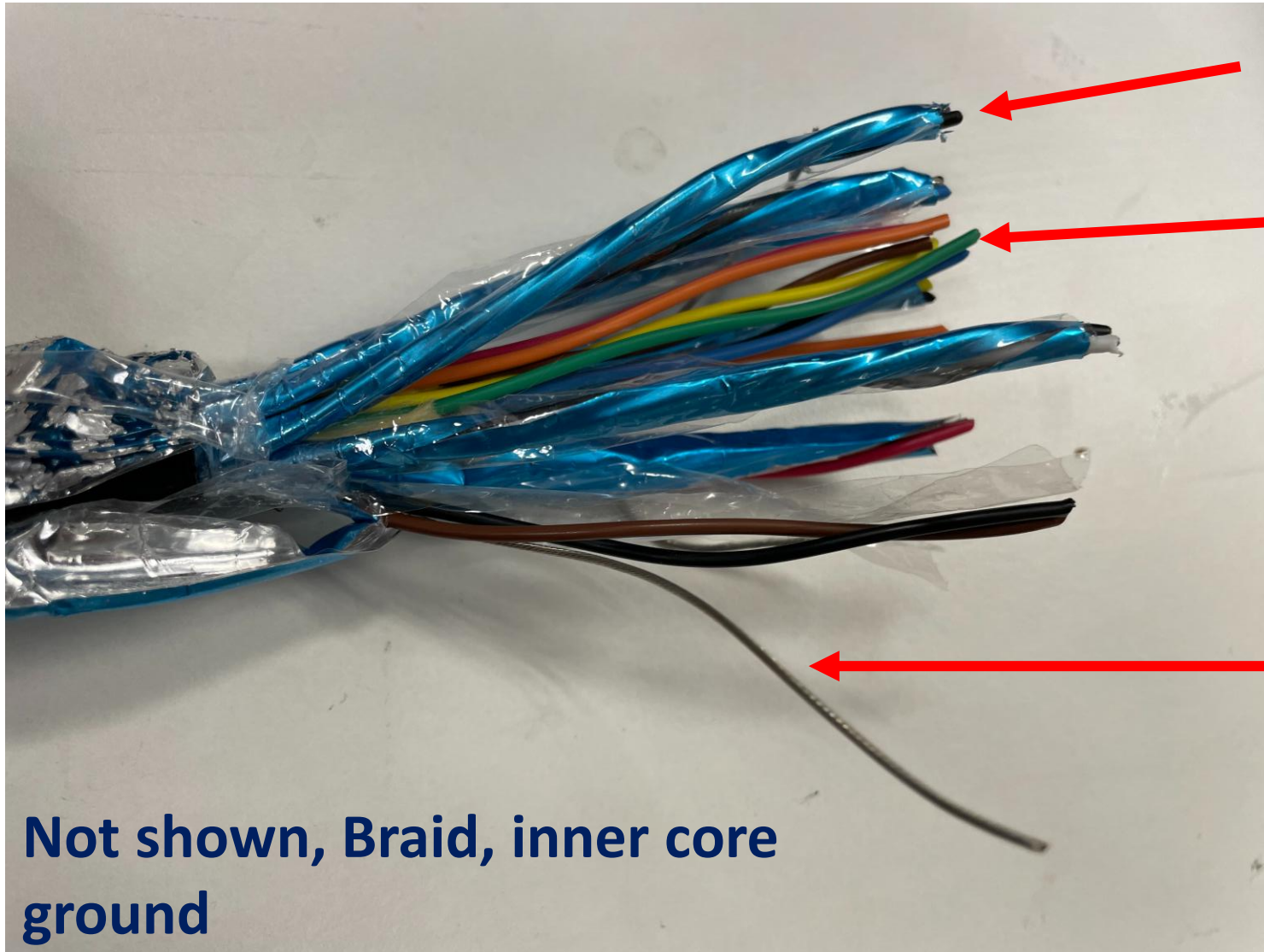

Twisted Pair

Center Core

Twisted pair shield

Not shown, Braid, inner core ground

Diode Test

- Ensure the diode position is selected on the voltmeter.
- Perform the test using both direct and reverse polarity:
- Reverse polarity: Connect + to U and – to T. The expected reading is approximately 0.6V or OL (depending on Beamformer board version).
- Forward polarity: Connect – to U and + to T. Since this is a Zener diode, the expected reading is around 1.9V (not 0V as with standard diodes).

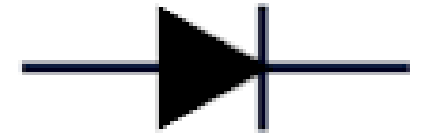

NOTE Forward bias is the most important of the two measurements. Results should be 1.X VDC.

Resistance Check Example

Table 24: Transducer Dry Connector Resistance Check

Description	Cable Dry Connector		Resistance	Your Readings
	From	To		
BEAM 1 XMIT to XMIT RTN (see note 8)	A	W	> 1.5 Mohms	1,768
BEAM 2 XMIT to XMIT RTN (see note 8)	D	C	> 1.5 Mohms	1,786
BEAM 3 XMIT to XMIT RTN (see note 8)	G	F	> 1.5 Mohms	1,744
BEAM 4 XMIT to XMIT RTN (see note 8)	K	J	> 1.5 Mohms	1,762
BEAM 1 RCV HI to BEAM 1 RCV LOW (see note 10)	e	M	< 15 ohms	2.8
BEAM 2 RCV HI to BEAM 2 RCV LOW (see note 10)	f	N	< 15 ohms	2.7
BEAM 3 RCV HI to BEAM 3 RCV LOW (see note 10)	g	P	< 15 ohms	2.8
BEAM 4 RCV HI to BEAM 4 RCV LOW (see note 10)	h	R	< 15 ohms	2.7
SHIELD to SHIELD	d	q	< 5 ohms	1.3
SHIELD to SHIELD	r	s	< 5 ohms	1.3
SHIELD to SHIELD	d	r	> 20 Mohms	OL
RCV ENABLE to VXDC GND (see note 9)	S	T	4.75 or 99 kohms	4.75 K
TEMP to TEMP RTN	i	j	11.3 kohms	7.88 K
VXDC to VXDC GND (see note 6)	U	T	Diode Check Reverse Bias Forward Bias	651.8 K 1.604 VDC
SDAT B to VXDC GND (see note 7)	k	T	5.9 kohms	OL
SDAT A to VXDC GND (see note 7)	m	T	> 20 Mohms	OL
SHIELD to ALL	B	ALL	> 20 Mohms	OL
SHIELD to ALL	E	ALL	> 20 Mohms	OL
SHIELD to ALL	H	ALL	> 20 Mohms	OL
SHIELD to ALL	V	ALL	> 20 Mohms	OL



Notice the similarity between beam one through four for both the transducer and receiver board.

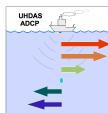

Transducer Dry Connector Resistance Check Troubleshooting Tips:

Troubleshooting Tips:

1. N/A = Not applicable, no check possible.
2. Some meters will read as OPEN or overload (OL) for resistances greater than 2Mohms. In most cases this is a pass. TRDI recommends using a multi-meter that will measure up to 20 M Ω .
3. If the TCM2 voltages are not present, the compass will not work, and the system will not operate in high gain mode. Therefore, the system will still collect valid data, but the profiling range will be greatly reduced.
4. If any one of the transmit wires are not correct, then the system will NOT function correctly, and MUST be repaired before accurate current data can be collected.
5. If one of the receive wires are not correct, then depending on the failure the system may still be able to function properly with 3 beam solutions.
6. VXDC to VXDC GND - This check needs to be done with the multi-meter in the diode check mode.
Connect the meter's positive lead to VXDC GND, and the negative lead to VXDC (reverse bias).
 - a) Measure a diode drop of ~0.6 VDC, or an overload (OL), depending on the Beamformer assembly version.
 - b) Reverse the leads (forward bias) and measure ~ 1.9 VDC.
7. SDATA and SDATB measurements only apply to Ocean Observer systems that have internal TCM2 compasses.
8. Each transmit pair resistance must be greater than 1.5 M Ω , and within 2 M Ω of the resistances on the other three transmit pairs.
9. Measure a resistance of 4.75 K or 99 K, depending on the Beamformer assembly version.
10. OO/OS 38 kHz receive pairs must be < 29 Ω . The OO/OS 38 kHz beamformer adds up to 14 Ω of internal resistance to each pair of receive lines.

Example of resistance checks that indicate failure

Table24: Transducer Dry Connector Resistance Check

Description	Cable Dry Connector		Resistance	Your Readings
	From	To		
BEAM 1 XMIT to XMIT RTN (see note 8)	A	W	> 1.5 Mohms	OL
BEAM 2 XMIT to XMIT RTN (see note 8)	D	C	> 1.5 Mohms	2.7 MΩ
BEAM 3 XMIT to XMIT RTN (see note 8)	G	F	> 1.5 Mohms	6 Ω
BEAM 4 XMIT to XMIT RTN (see note 8)	K	J	> 1.5 Mohms	2.6 MΩ
BEAM 1 RCV HI to BEAM 1 RCV LOW (see note 10)	e	M	< 15 ohms	3.2 Ω
BEAM 2 RCV HI to BEAM 2 RCV LOW (see note 10)	f	N	< 15 ohms	3.1 Ω
BEAM 3 RCV HI to BEAM 3 RCV LOW (see note 10)	g	P	< 15 ohms	3.2 Ω
BEAM 4 RCV HI to BEAM 4 RCV LOW (see note 10)	h	R	< 15 ohms	13.5 MΩ
SHIELD to SHIELD	d	q	< 5 ohms	3.1 MΩ
SHIELD to SHIELD	r	s	< 5 ohms	3.1 MΩ
SHIELD to SHIELD	d	r	> 20 Mohms	OL
RCV ENABLE to VXDC GND (see note 9)	S	T	4.75 or 99 kohms	~70 MΩ
TEMP to TEMP RTN	i	j	11.3 kohms	11.2 KΩ
VXDC to VXDC GND (see note 6)	U	T	Diode Check Reverse Bias Forward Bias	OL 0.204 VDC
SDAT B to VXDC GND (see note 7)	k	T	5.9 kohms	OL
SDAT A to VXDC GND (see note 7)	m	T	> 20 Mohms	OL
SHIELD to ALL	B	ALL	> 20 Mohms	OL
SHIELD to ALL	E	ALL	> 20 Mohms	OL
SHIELD to ALL	H	ALL	> 20 Mohms	OL
SHIELD to ALL	V	ALL	> 20 Mohms	OL

Beam 1 on the transmit portion of the beamformer board appears to have failed. Higher resistance between reciprocal beam pairs typically indicates a cable or transducer issue. Resistance readings on the receive portion of the beamformer board are highly inconsistent, showing megaohms instead of ohms. Diode check reading looks suspect. This may all point to:

- A damaged or corroded cable
- A flooded connector impacted by corrosion
- A faulty beam former board

Overall Assessment:
These results strongly suggest a severely compromised system.

Recommendation: If abnormal data is observed or a system issue is suspected, perform a dry-side resistance check as one of the first troubleshooting steps. This provides a clear diagnostic baseline and helps identify potential failures early.

Tip: you can always compare a resistance check to the baseline resistance check provided when the system was installed to gain a better understanding of basic system health how your system is aging.

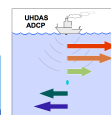

Things to look out for

Corrosion or evidence of flooding

Scorched pins or scorch marks on the connector plug

Cuts or abrasions on the wet end of the cable, they may lead to flooding

Cable fatigue or excessive cable wear

Crushed cable



Diagnosing Failures – Ocean Surveyor Deckbox

- When to "disconnect the deck unit and run the PT tests again"
 - If PT200 (PT3 & PT6) continue to fail
 - Run the Cable checks
 - If all the cable checks are good, then EMI could be getting in at the deckbox
 - If the PT200 fails with the cable disconnected then the deckbox may be getting EMI
 - Run the PC2 test to see if deckbox is ok
 - No Temp data can mean bad deckbox
 - Single beam issues are signs of bad deckbox
 - Test the motherboard in the deckbox.
 - Ask RDIFS or UNOLS pool for a test deckbox

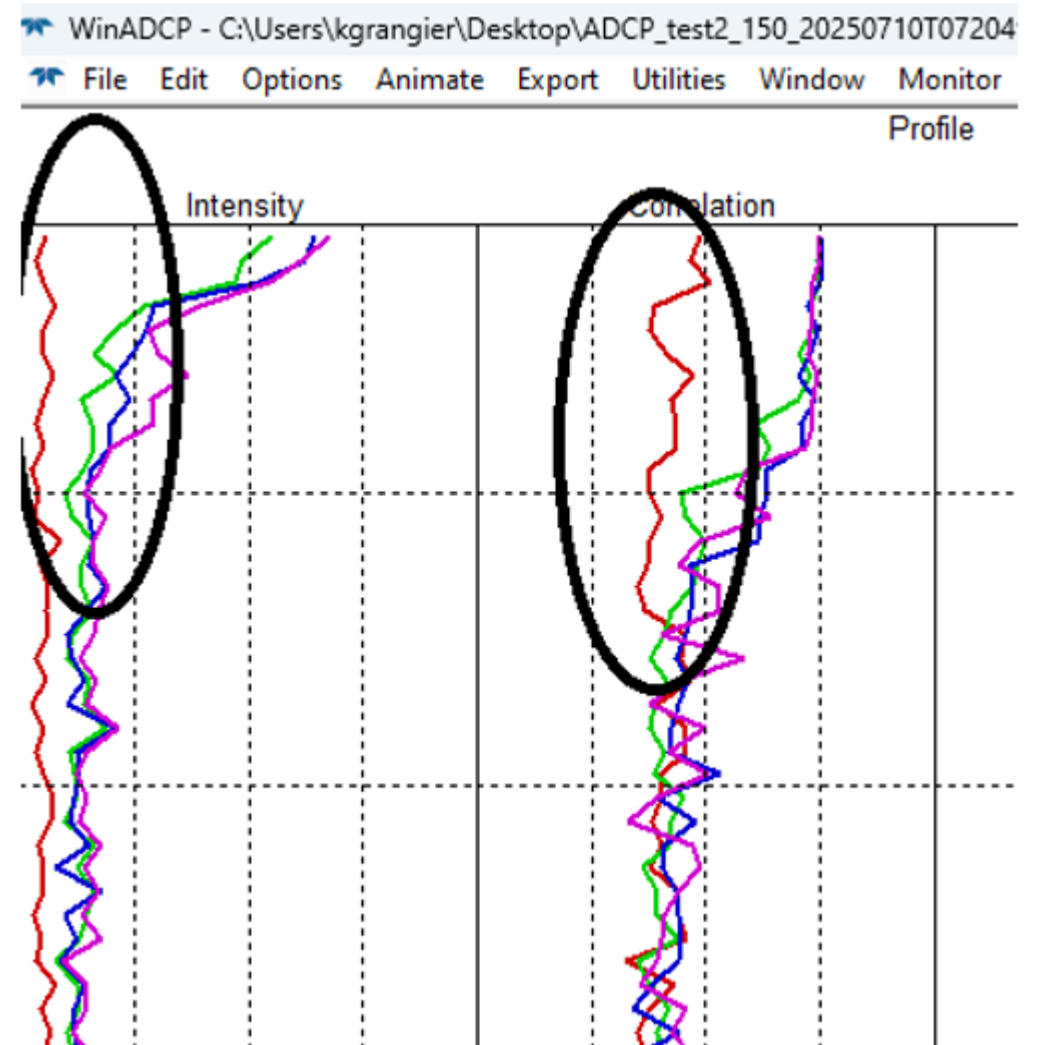

Diagnosing Failures – Ocean Surveyor

- FFT (Fast Fourier Transform)
 - Acoustic Interference

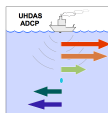
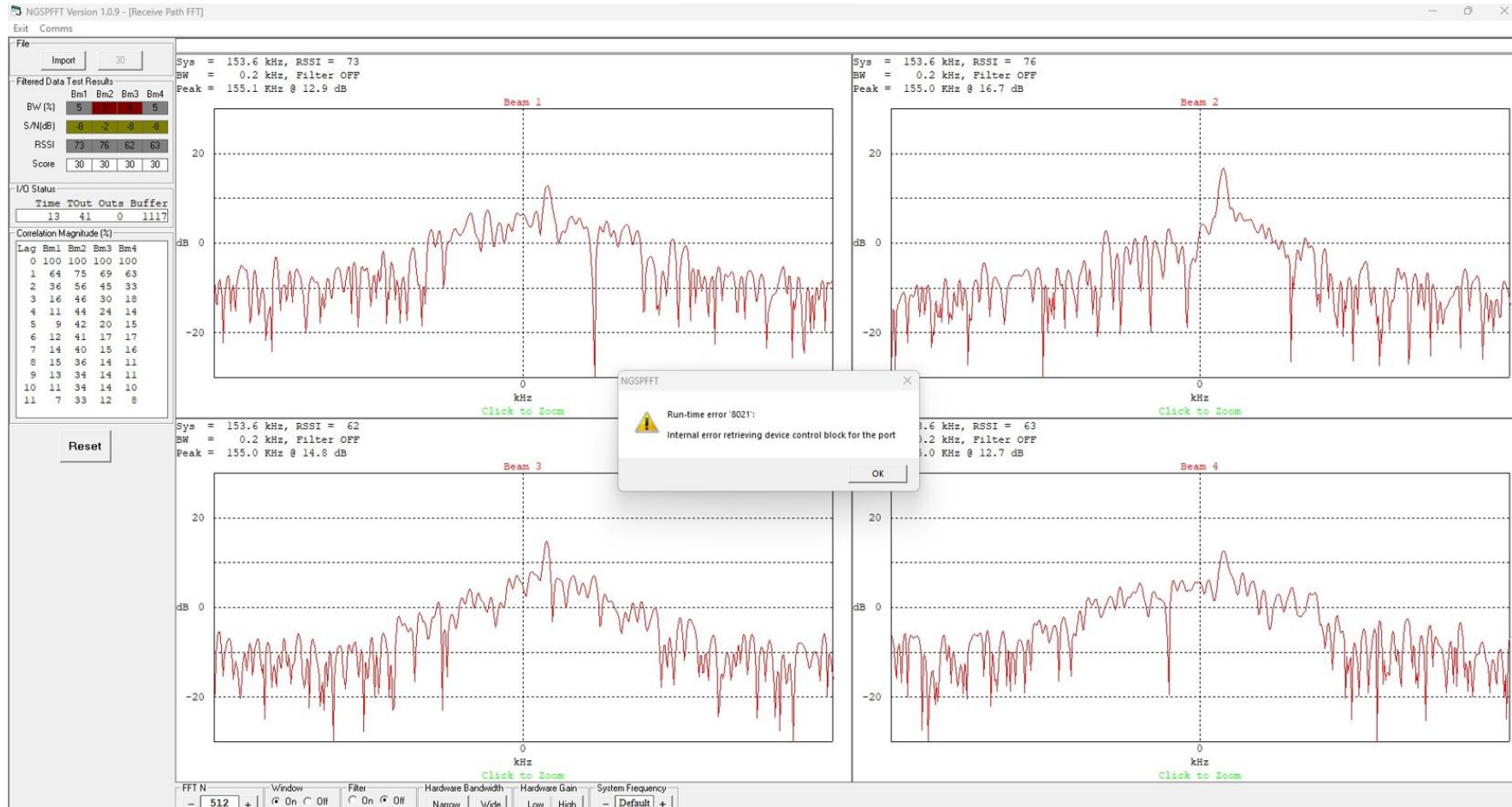

Diagnosing Failures – Ocean Surveyor

- FFT
 - EMI on Cable

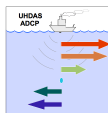
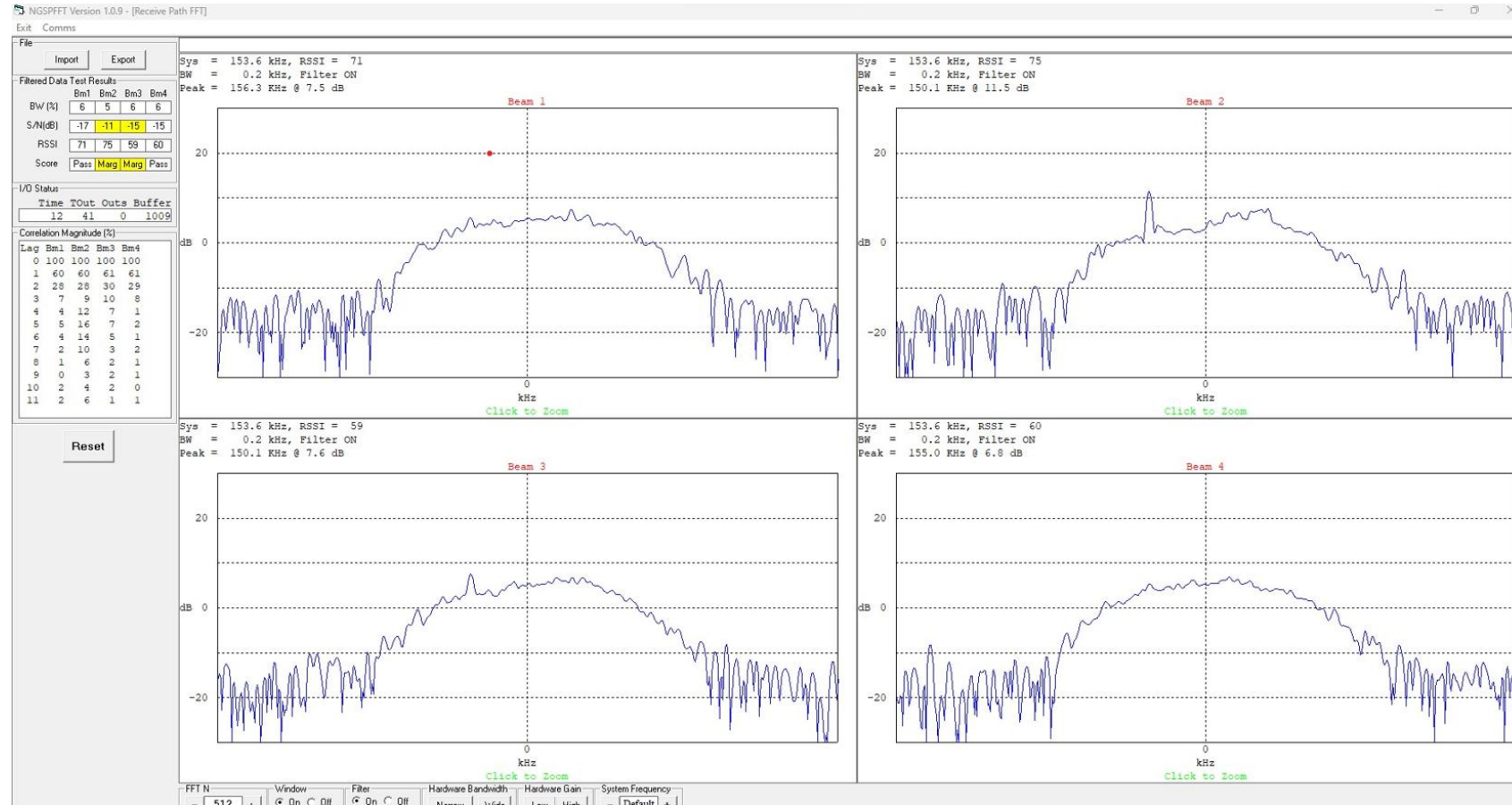

Diagnosing Failures – Ocean Surveyor Data Review

- Single Ping Data Examples

- https://currents.soest.hawaii.edu/uhdas_dot_org/bad_beams/index.html

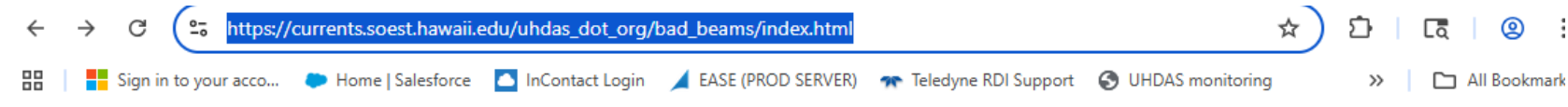

ADCP thumbnails

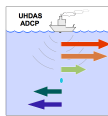
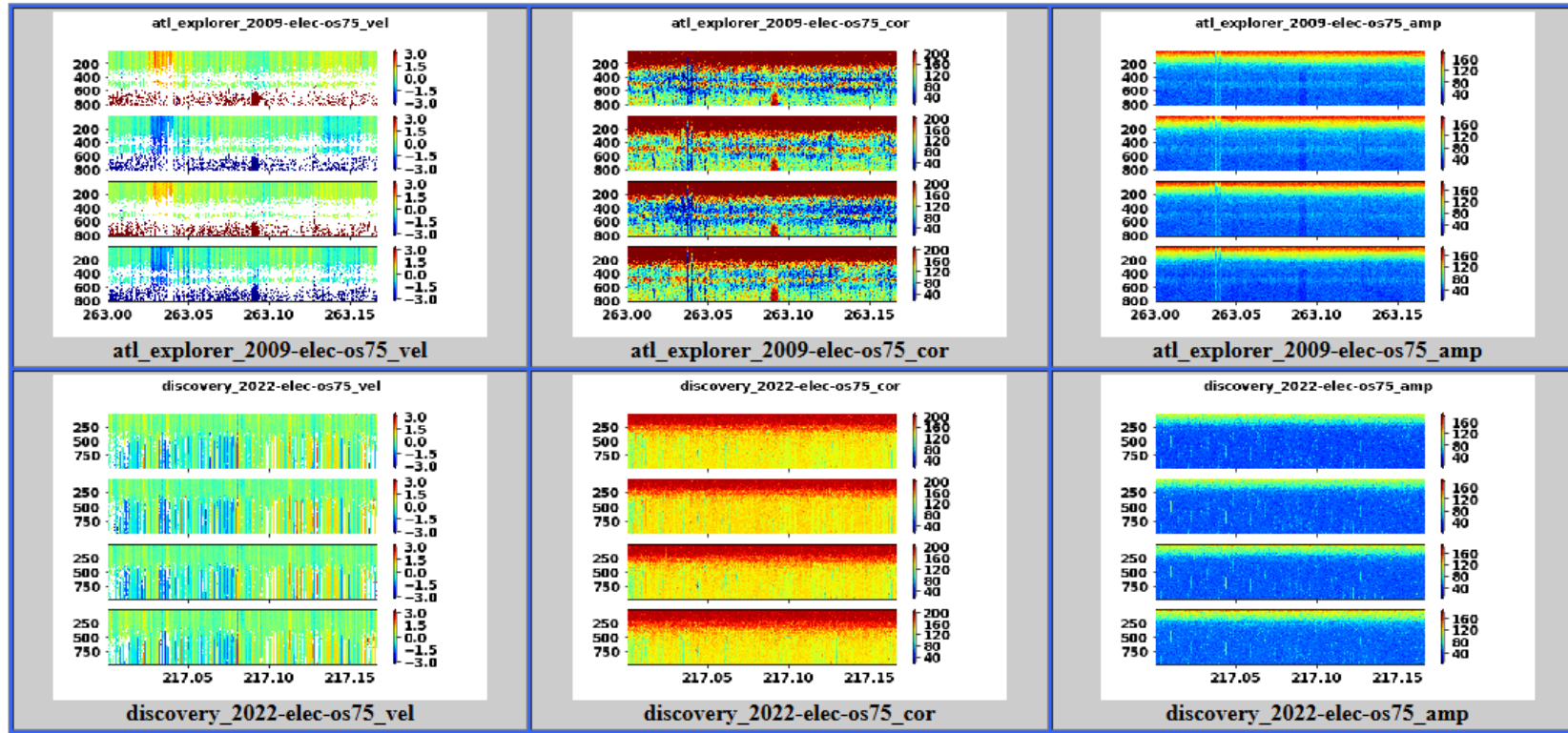

Diagnosing Failures – Ocean Surveyor Data Review

- Thermistor
 - Temperature pegged at about 92.56C
 - Indicates a short probably due to water ingress into the electronics
 - Failure is likely in days to months
 - Temperature will likely have started jumping prior to pegging
 - Frequent or noisy temperatures (spikes of +/- 10C) indicate electrical noise
 - Move the deck unit closer to the transducer to shorten the cable run
 - Move EMF sources away from the cable
 - Occasional temperature spikes of a few degrees might be coming from another sonar
 - Ignore, unless there is a coincident bias in the velocities

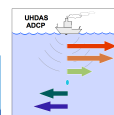

• Workhorse

- ADCP design where errors can get in
- Diagnosing Failures

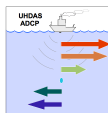

ADCP design where errors can get in -WH

- Workhorse
 - 4 independent ceramic transducers



ADCP design where errors can get in -WH

- Workhorse
 - 4 independent ceramic transducers



Peeling on transducer face can lead to water ingress and flooding

ADCP design where errors can get in -WH

- Workhorse
 - 4 independent ceramic transducers
 - **Other Electronics**

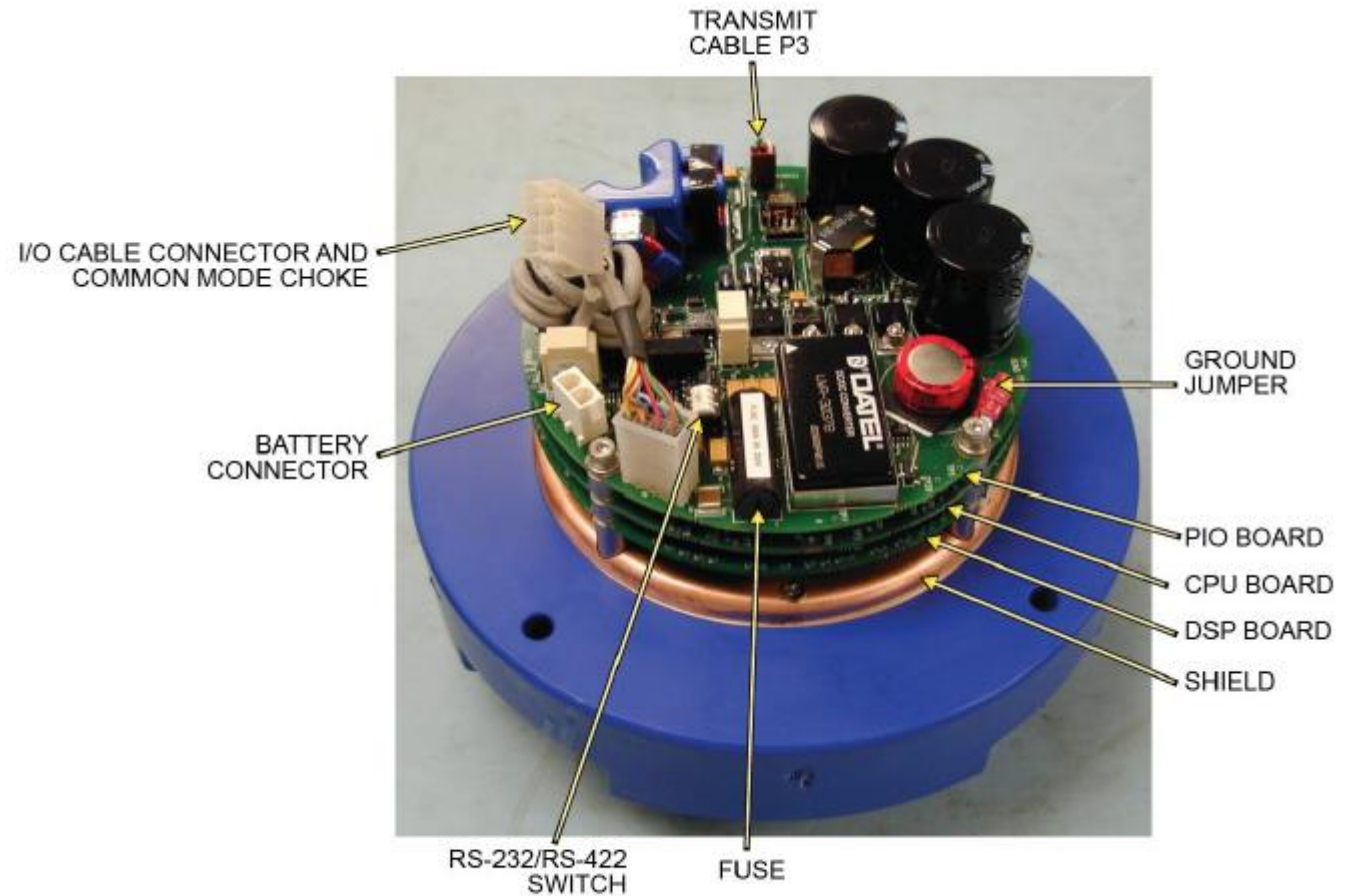

Figure 59. Original Workhorse Board Stack

ADCP design where errors can get in -WH

- Workhorse
 - 4 independent ceramic transducers
 - **Other Electronics**

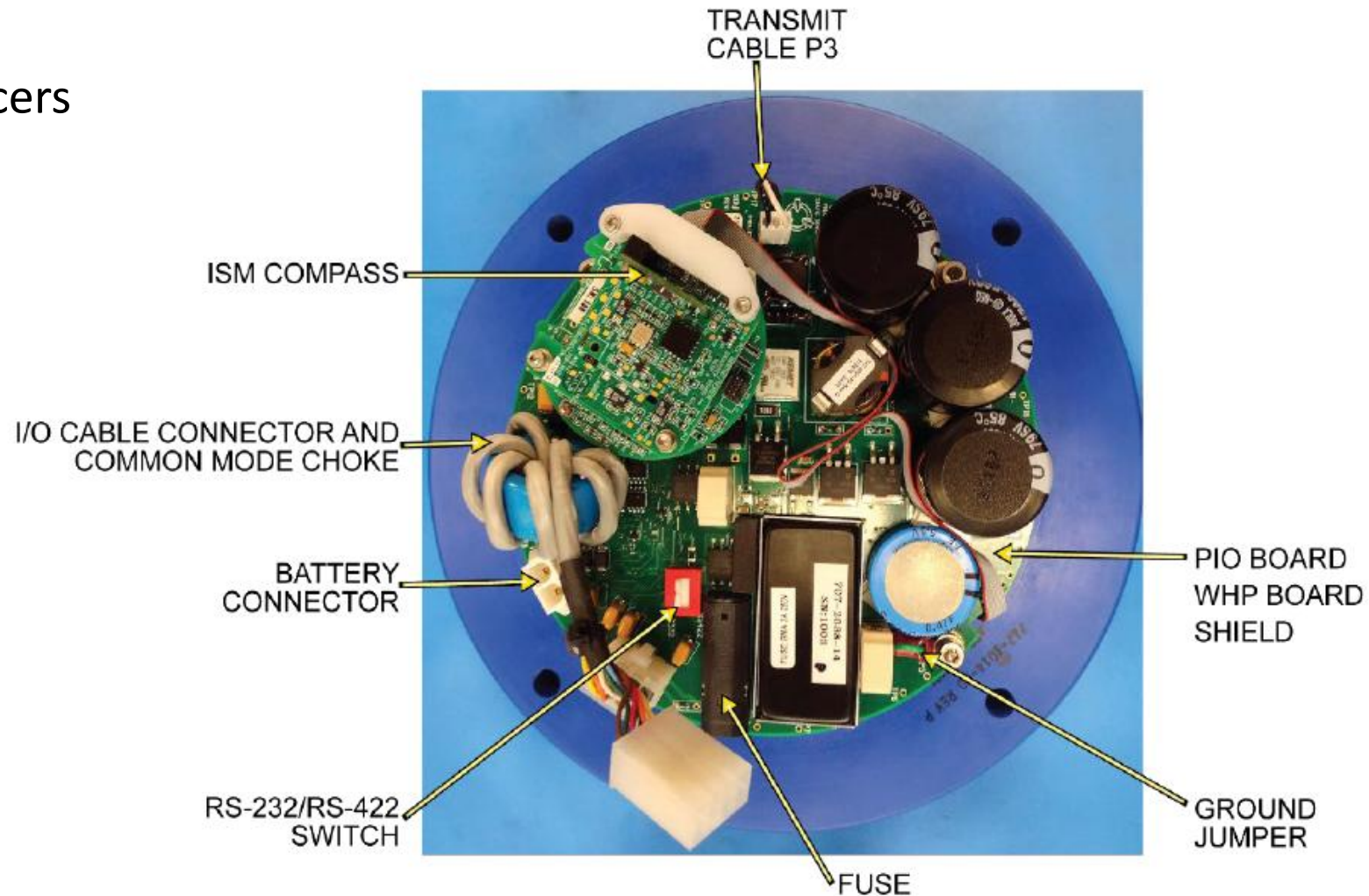

Figure 56. Workhorse II Board Stack

ADCP design where errors can get in -WH

- Workhorse

- 4 independent ceramic transducers
- **Other Electronics**

Built in Tests (PT Commands)

- PT2 – Ancillary System Data
- PT3 = Receive Path
- PT4 = Transmit Path
- PT5 = Electronics Wrap Around
- PT6 = Receive Bandwidth
- PT7 = RSSI Bandwidth
- PT200 = All tests
- NOTE: Add 100 for automatic test repeat
- NOTE: For best results test in water

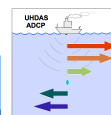

Diagnosing Failures - Workhorse

- Fault logs (FD command)
 - Also run PDO Check Tool
- Running the PT tests
- Run WHFFT

```
>fd
Total Unique Faults = 5
Overflow Count = 0
Time of first fault: 21/05/13,12:32:33.18
Time of last fault: 21/07/08,13:14:43.54

Fault Log:
Entry # 0 Code=0206h Count= 6 Delta=1414772 Time=21/05/19,15:20:36.64
Parameter = 00018F00h
Timeout waiting for device ready.
Entry # 1 Code=0a0ah Count= 1 Delta= 0 Time=21/07/08,13:14:42.04
Parameter = 00000000h
Fluxgate circuit excessive offset drift.
Entry # 2 Code=0a0bh Count= 1 Delta= 0 Time=21/07/08,13:14:42.54
Parameter = 00000000h
Tilt circuit excessive offset drift.
Entry # 3 Code=0a0dh Count= 1 Delta= 0 Time=21/07/08,13:14:43.04
Parameter = 00000000h
Attitude temperature sensor out of range.
Entry # 4 Code=0a17h Count= 1 Delta= 0 Time=21/07/08,13:14:43.54
Parameter = 00000000h
Ambient temperature sensor out of range.
End of fault log.
```

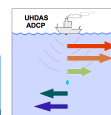
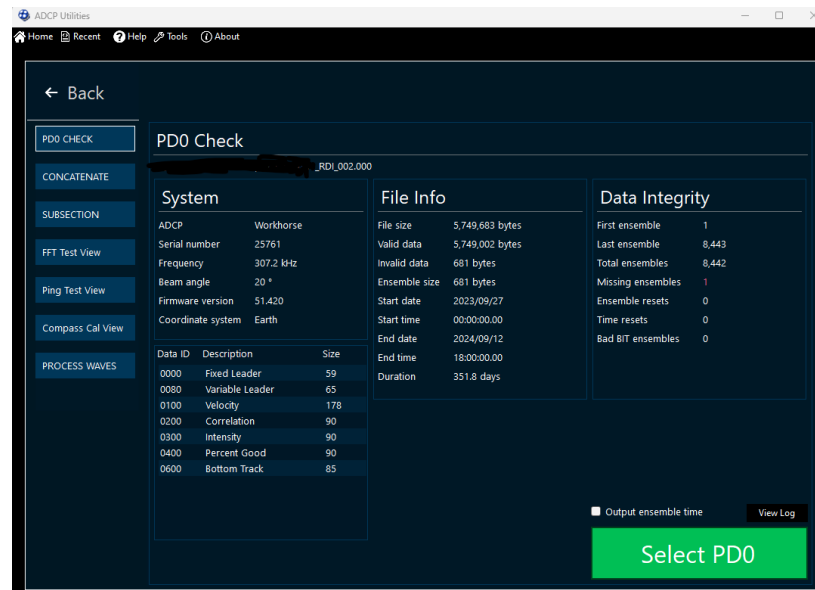

ADCP design where errors can get in -WH

- Workhorse
 - 4 independent ceramic transducers
 - Other Electronics
 - Baud rate
 - RS-232 vs 422

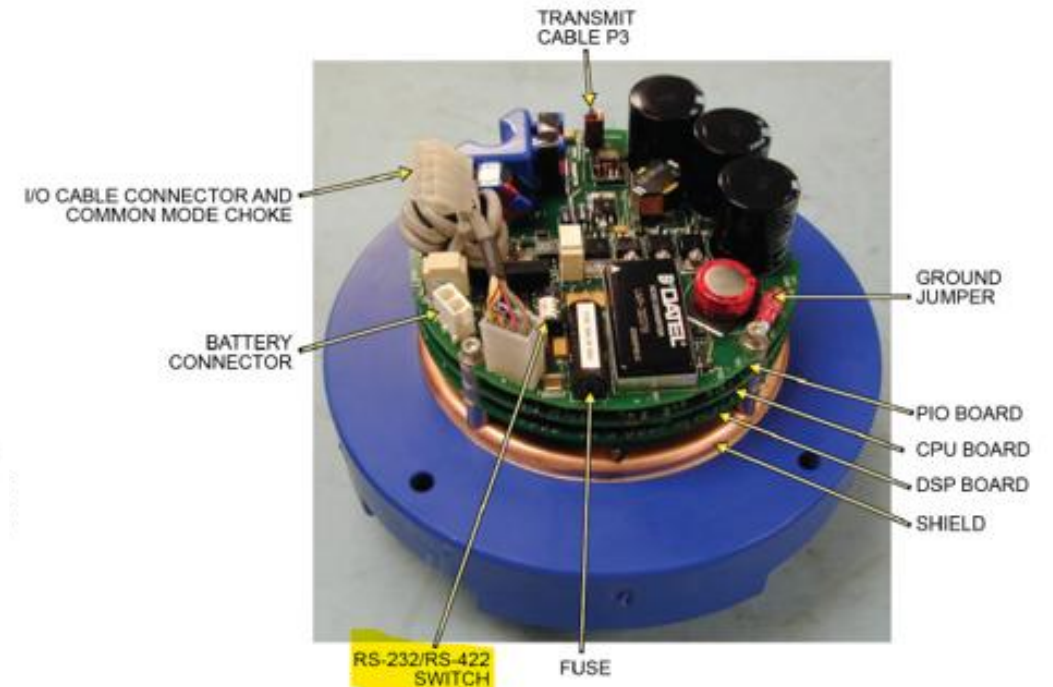
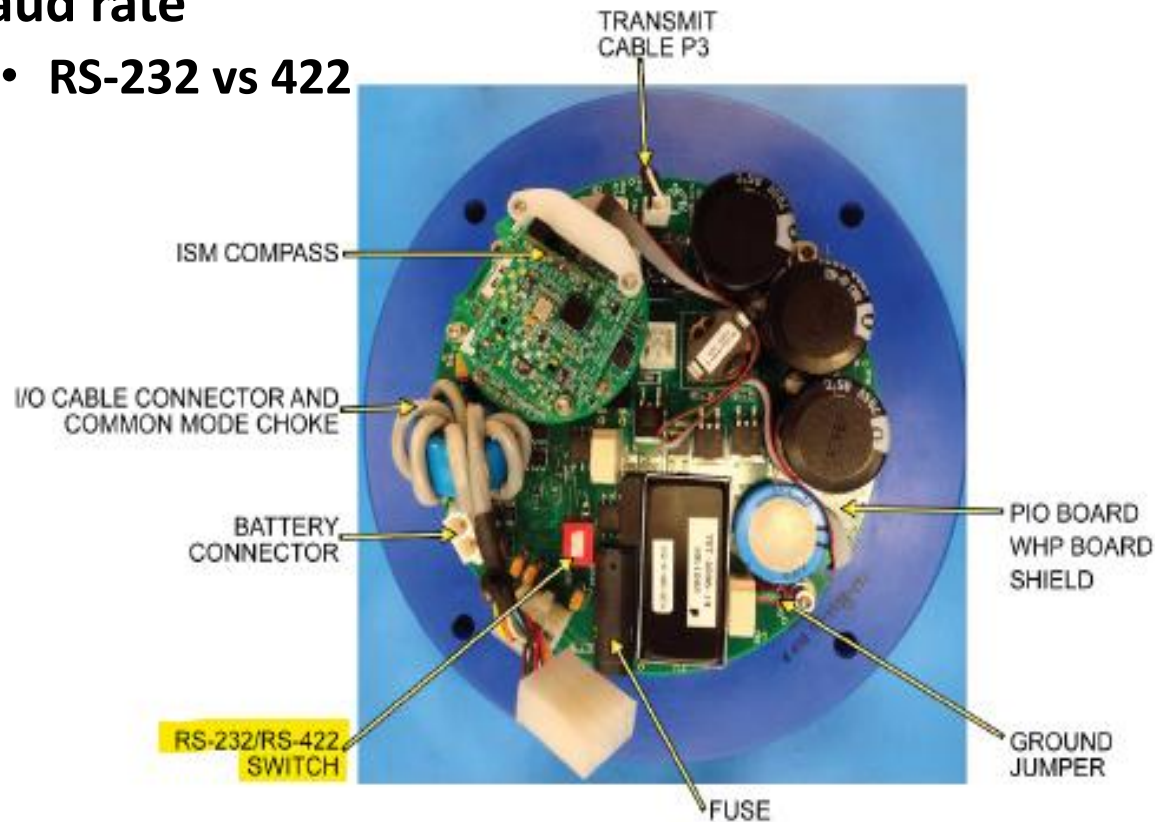

Figure 59. Original Workhorse Board Stack

ADCP design where errors can get in -WH

- Workhorse

- 4 independent ceramic transducers
- Other Electronics
- Baud rate
 - RS-232 vs 422
- **cable is power & comms**

Comms, Loop Back Test:

- For RS-232 communications, short pins 1 and 2 together on the female 7-pin connector that was plugged into the WorkHorse
- For RS-422, connect a jumper between pin 2 to pin 6 and another jumper between pins 1 to pin 5 of the underwater connector at the WorkHorse end of the cable.

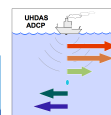

ADCP design where errors can get in -WH

- Workhorse
 - 4 independent ceramic transducers
 - Other Electronics
 - Baud rate
 - RS-232 vs 422
 - **cable is power & comms**

Power:

Monitor/Sentinel

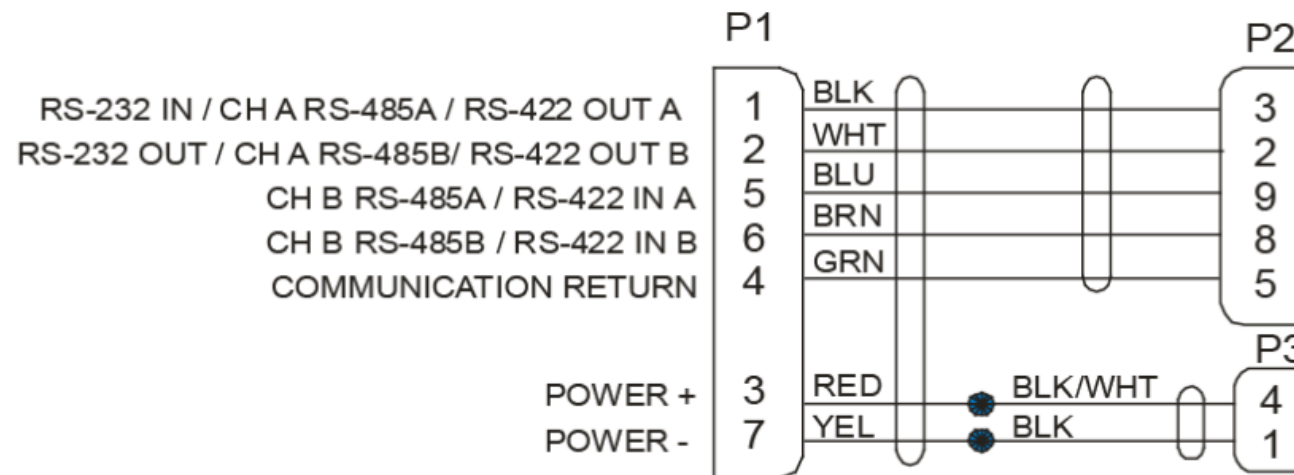

View A - A
J1 Wire Side

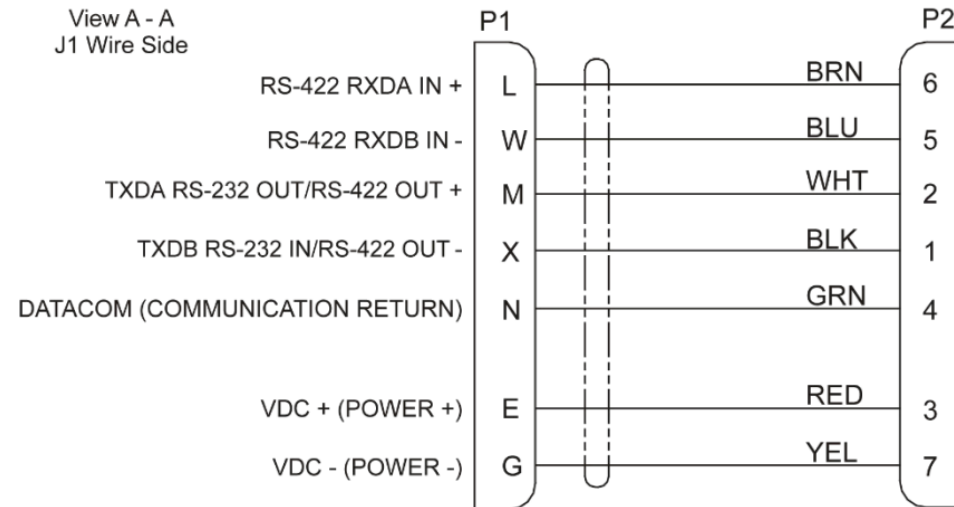

Mariner

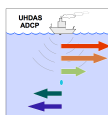

ADCP design where errors can get in -WH

- Workhorse

- 4 independent ceramic transducers
- Other Electronics
- Baud rate
 - RS-232 vs 422
- cable is power & comms
- **deck unit is power + comms**

Deck Unit:

- Check fuses:
 - 3 fuses total

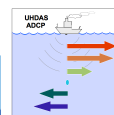

ADCP design where errors can get in -WH

- Workhorse
 - 4 independent ceramic transducers
 - Other Electronics
 - Baud rate
 - RS-232 vs 422
 - cable is power & comms
 - **deck unit is power + comms**

Deck Unit:

- Check fuses:
 - 3 fuses total

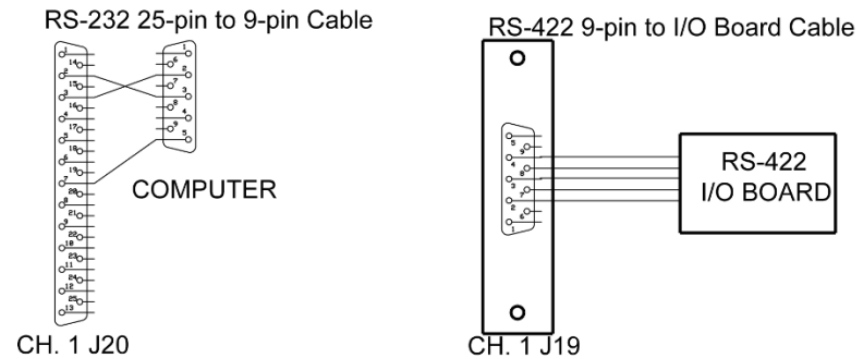

Cable Type	ADCP Signal	Chassis	Computer	Computer Signal
RS-232 25-pin to 9-pin	DATA IN DATA OUT GND	2 3 7	3 2 5	DATA OUT DATA IN GND
RS-422 9-pin to I/O board	DATA IN A DATA OUT A COMMON DATA IN B DATA OUT B	2 4 3 7 8	- - - - -	DATA OUT A (+) DATA IN A (+) COMMON DATA OUT B (-) DATA IN B (-)

Figure 21. Mariner Deckbox to Computer Serial Cable

ADCP design where errors can get in -WH

- Workhorse
 - 4 independent ceramic transducers
 - Other Electronics
 - Baud rate
 - RS-232 vs 422
 - cable is power & comms
 - deck unit is power + comms
 - **Benchtop cable power supply**
 - **Notorious for EMI, made for bench top testing.**



Contacting RDIFS

- Did UHDAS contact you?
- When to contact concerning failures?
- What to send?
 - serial numbers
 - frequency
 - Log Files (PT Tests)
 - Cable checks
 - FFT
 - Pictures
- Figures showing the issue
 - raw beam velocities
 - signal return correlation
- ENR or *.raw data from the bad period and a good period for comparison
- Approving UHDAS to send raw data to RDIFS

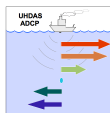

New UHDAS SOP for Ocean Surveyors

- At least yearly, eg. on the first cruise out of a long in-port period
 - in deep water, underway
 - PT200
 - PT5
 - PT3
 - PT6
- Save the results in a file with the date, name and serial number of the sonar
- Cable Resistance Checks
- Lots of photos of installation

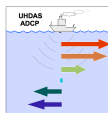

Access to Manuals and Software/Firmware Portal

- ADCP.com
- <https://www.teledynemarine.com/support/RDI>
- <https://www.teledynemarine.com/en-us/support/Pages/RDI.aspx>
- Manuals
 - [OS Deployment Guide](#)
 - [Ocean Surveyor / Ocean Observer Installation Guide](#)
 - [Ocean Surveyor / Ocean Observer Technical Manual](#)
 - [Mariner Deployment Guide](#)
 - [WorkHorse Operation Manual](#)
 - [WorkHorse Commands and Output Data Format](#)
 - [WH2 Mariner Deployment Guide](#)
 - [WH2 Operation Manual](#)

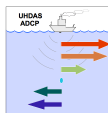

RDI Poway support contacts



Grant Jennings, Product Line Director

Office: +1-858-842-2702

Mobile: +1-858-829-2837

Grant.Jennings@Teledyne.com



Paul Devine, Subject Matter Expert

Office: +1-858-842-2671

Mobile: +1-858-254-7204

Paul.Devine@Teledyne.com



Harold Thomas, Repair Manager

Office: +1-858-842-2705

Mobile: +1-858-335-1471

Harold.Thomas@Teledyne.com



Cindy Weems, Sales Admin Manager

Office: +1-858-842-2632

Mobile: +1-858-208-8051

Cindy.Weems@Teledyne.com



Chris Rockey, Field Service Engineer

Office: +1-858-842-2951

Chris.Rockey@Teledyne.com



Paul Chua, Field Service Engineer

Office: +1-858-842-2631

Mobile: +1-858-208-8088

Paul.Chua@Teledyne.com



**Sarah Ruth Merrigan,
Field Service Engineer**

Office: +1-858-842-2781

Mobile: +1-858-375-8336

Sarahruth.merrigan@Teledyne.com



Manolette Almazan, Sales Admin

Office: +1-858-842-2709

Manolette.Almazan@Teledyne.com



Kean Vorn-Valdez, Customer Service Specialist

Office: +1-858-842-2613

Kean.Vorn-Valdez@Teledyne.com

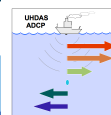

UHDAS support contacts

UHDAS@Hawaii.edu

<https://currents.soest.hawaii.edu/home/>

Julia M. Hummon



Eric Firing



Drew Frambach



David Vadnais

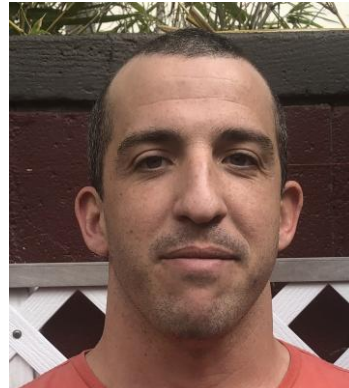

Jamie Ash



Lauren Yumol

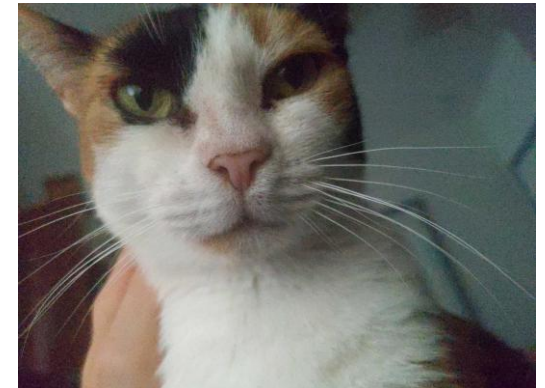

Ezra Varady

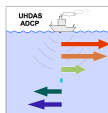



TELEDYNE MARINE
Everywhere you look™

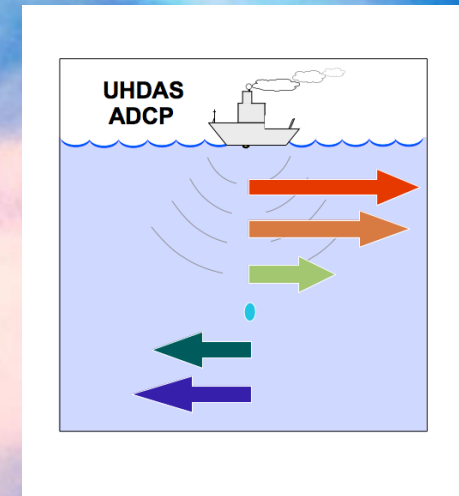

San Diego: Teledyne Marine 858-842-2600
24 Hour Field Support 858-842-2700

RDIFS@Teledyne.com

France: +33 492 110 930

RDIEFS@teledyne.com

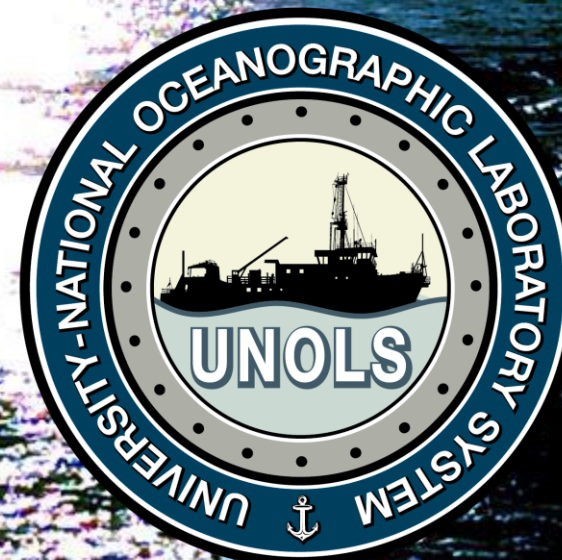



Teledyne Technologies

October 2025

