

# DESH-5 Winch Upgrade & Refurbishment

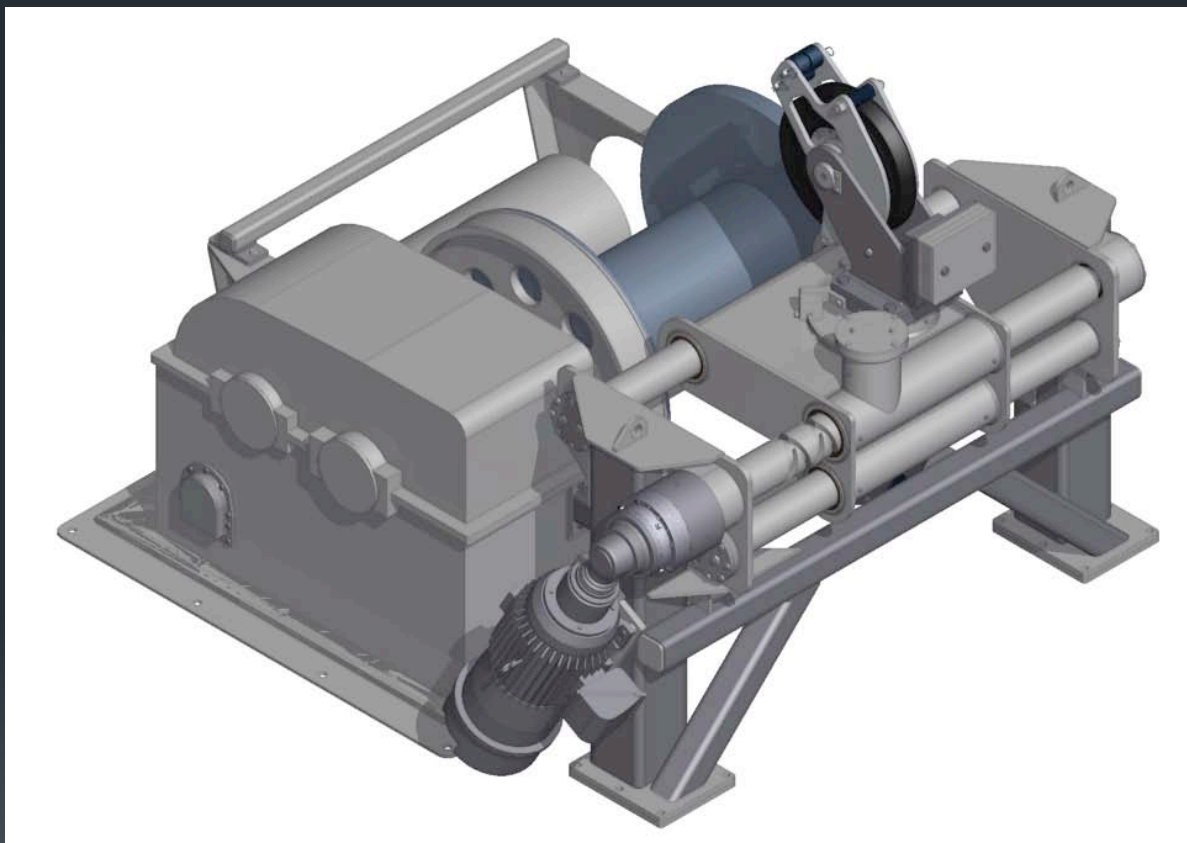

Similar in concept to CAST-6 recently installed on R/V Roger Revelle



# Project Outline

- Upgrade UNOLS fleet DESH-5 Winches to eliminate back bending of wires
- Refurbish existing DESH-5 Winches
- Upgrade controls to provide Heave Compensation plus Render/Recover capabilities

# Upgraded DESH-5 Winches

- Old level wind system removed
- Add an electrically driven “separate” level wind system on the “back side” of the winch
- Add a flagging block to the top of the level wind
- Remove band brake
- Lock in single speed
- Eliminate the clutch
- Upgraded coupling
- Upgraded brake
- New winch SCR drive for both the winch & the level wind
- Add Heave Comp & Render / Recover capability
- Refurbish winch – inspect, bearings, seals, motor, blast / paint
- MCD Produced plus O&M Manual update

# Plan

- Atlantis - done
- Marcus Langseth – done
- Revelle – refurb/upgrade of winch underway at Markey
- Thomas G. Thompson – Start first winch shortly
- Atlantic Explorer – 2015?

- **Contact:**

Doug Russell

[dgruss@uw.edu](mailto:dgruss@uw.edu)

206-543-5062 / 206-321-5320



**R/V Atlantis**

**R/V Marcus Langseth**

