

# Replacement Human Occupied Vehicle (RHOV)

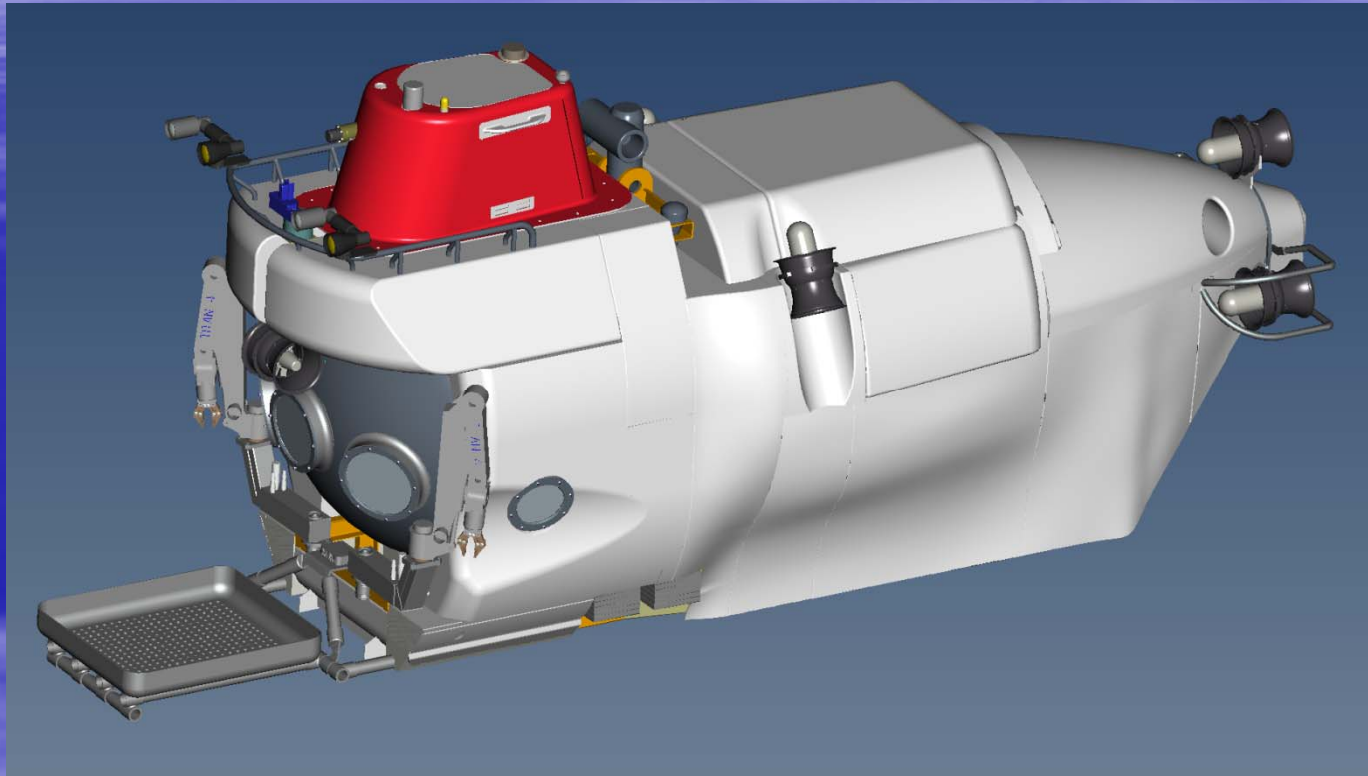

UNOLS Council  
October, 2010

Brian Midson

# Proposed Phase-I (4500m) Vehicle

Newly constructed sphere (green)

Existing *Alvin* components (gray)

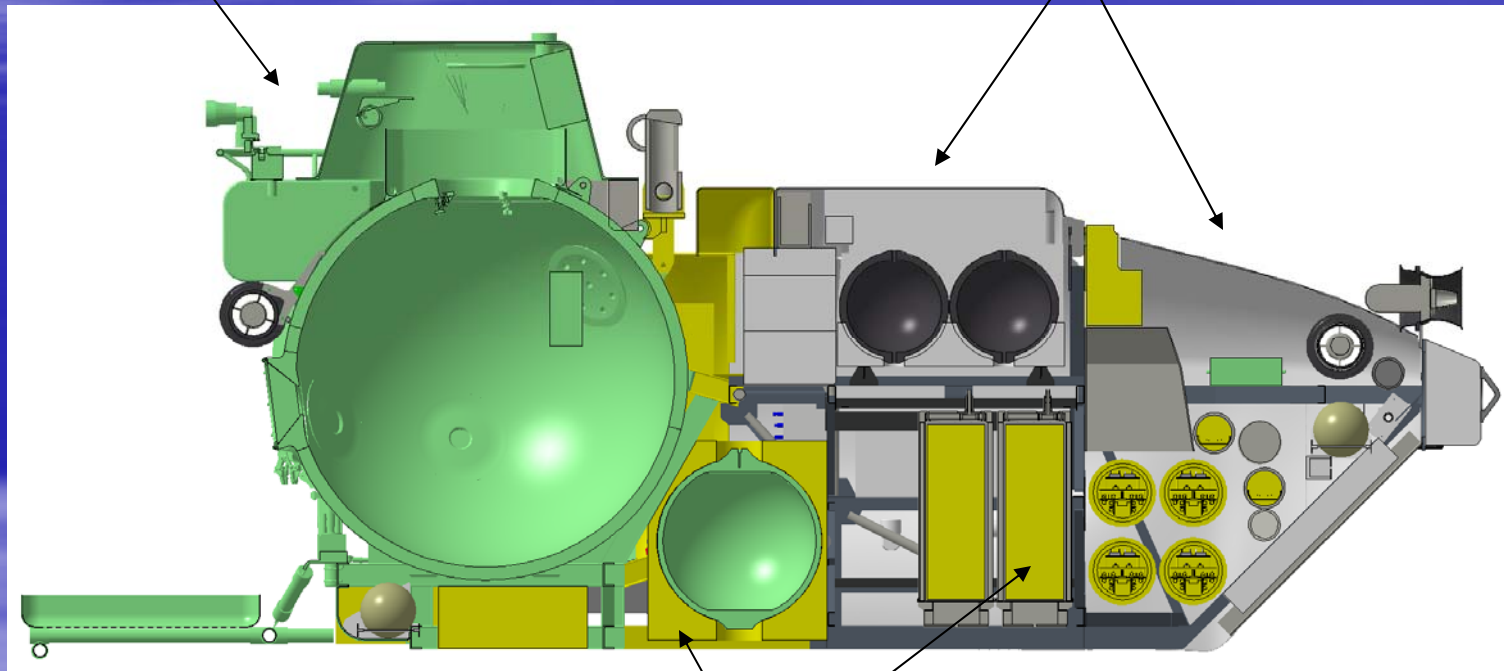

Primary vehicle components to be developed:

Syntactic foam, batteries (yellow)

# Sphere

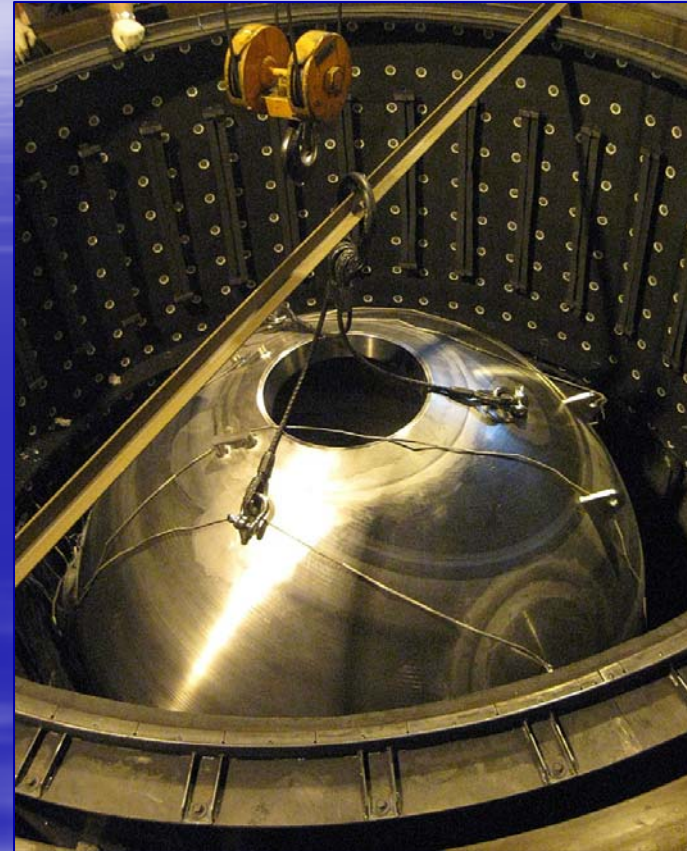

# Post-Weld Heat Treatment



# FDR



- Final Design Review, September 2010
  - Project should continue, budget sound
  - Dual NAVSEA/ABS certification/classification
  - Quantify SMR's
  - Inform and involve stakeholders: science and operations
  - Schedule is of concern\*
  
- Sphere Delivery, May 2011\*
  
- Initial Sea Trials, Early-Mid 2012\*

Show  
the  
Movie!