

# Replacement Human Occupied Vehicle

DESSC  
December 2008

## *Alvin Upgrade Project*

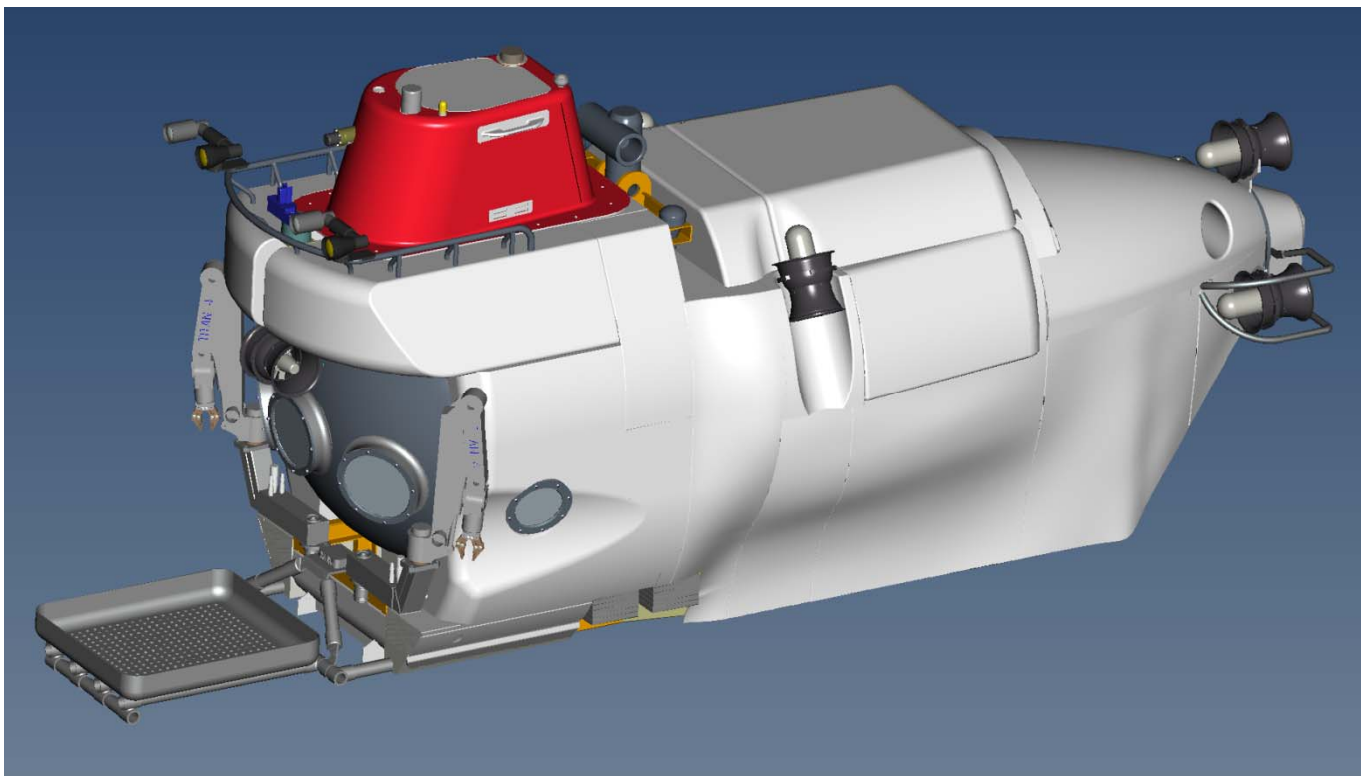

# Replacement Human Occupied Vehicle Outline

DESSC  
December 2008

- History of the RHOV Project
- *Alvin Upgrade* Project – Phased Approach
- NSF Requirements
- Program Management
- Project's Original Goals
- Specific Capabilities
- Science Outfitting Plans
- Changes to Mode of Operation
- Risk Mitigation
- Impact to Alvin Operations and Overhaul Schedule
- Project Timeline
- Personnel Sphere Status



# Replacement Human Occupied Vehicle

DESSC  
December 2008

## History of the RHOV Project

- **2004** National Research Council (NRC) Report
- **Jul 04** NSF awarded Cooperative Agreement to WHOI
- **Jul 04** Replacement Human Occupied Vehicle Oversight Committee (**RHOC**) formed
- **Oct 05** Sphere awarded to Southwest Research Institute (SwRI)
- **Jun 07** RHOV preliminary award to Lockheed Martin
- **Nov 07** Lockheed Martin's PDR
- **Jan 08** WHOI analysis of detailed costs
- **Feb 08** RHOC review of detailed costs



# Replacement Human Occupied Vehicle

## History of the RHOV Project

DESSC  
December 2008

- **Jun 08** DESSC and RHOC review of options
  - Obtain additional funding to complete RHOV
  - Upgrade *Alvin* in stages
  - Terminate RHOV program
- **Sep 08** *Alvin Upgrade* Project - Phased Approach adopted
- **Sep 08** Stop work order issued to Lockheed Martin
- **Oct 08** Document submittals to NSF
- **Nov 08** RHOC review of WHOI documents and project plan
- **Dec 08** RHOC report submitted to NSF



# Alvin Upgrade Project

## Phased Approach

DESSC  
December 2008

### Concept

- Upgrade *Alvin* with 6,500 meter titanium sphere being produced by SwRI
- Satisfy RHOV goals to extent possible with remaining funds
- Benefit from Lockheed Martin's design effort for RHOV
- Implement remaining RHOV goals in the future
- Achieve goal of providing the scientific community with a 6500 meter HOV, in stages



# Alvin Upgrade Project

## Hydrodynamic Shape

DESSC  
December 2008



Color Codes:

RHOV	Green
New	Yellow
<i>Alvin</i>	Grays

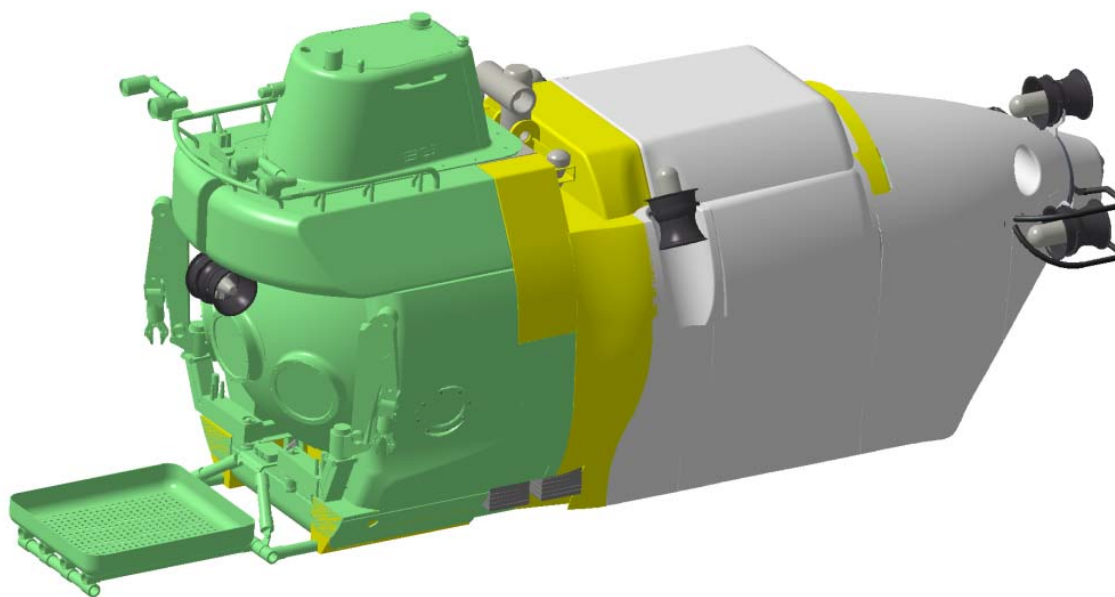

# Alvin Upgrade Project

## Phased Approach

DESSC  
December 2008

### Phase 1 – 4,500 meters

- Titanium sphere
  - improved field of view
  - increased internal volume
  - improved ergonomics
- Lithium-ion battery system
- State-of-the-art command and control system
- Improved lighting
- Hi-definition camera & video systems

### Phase 2 – 6,500 meters



# Alvin Upgrade Project Organizational Structure

DESSC  
December 2008

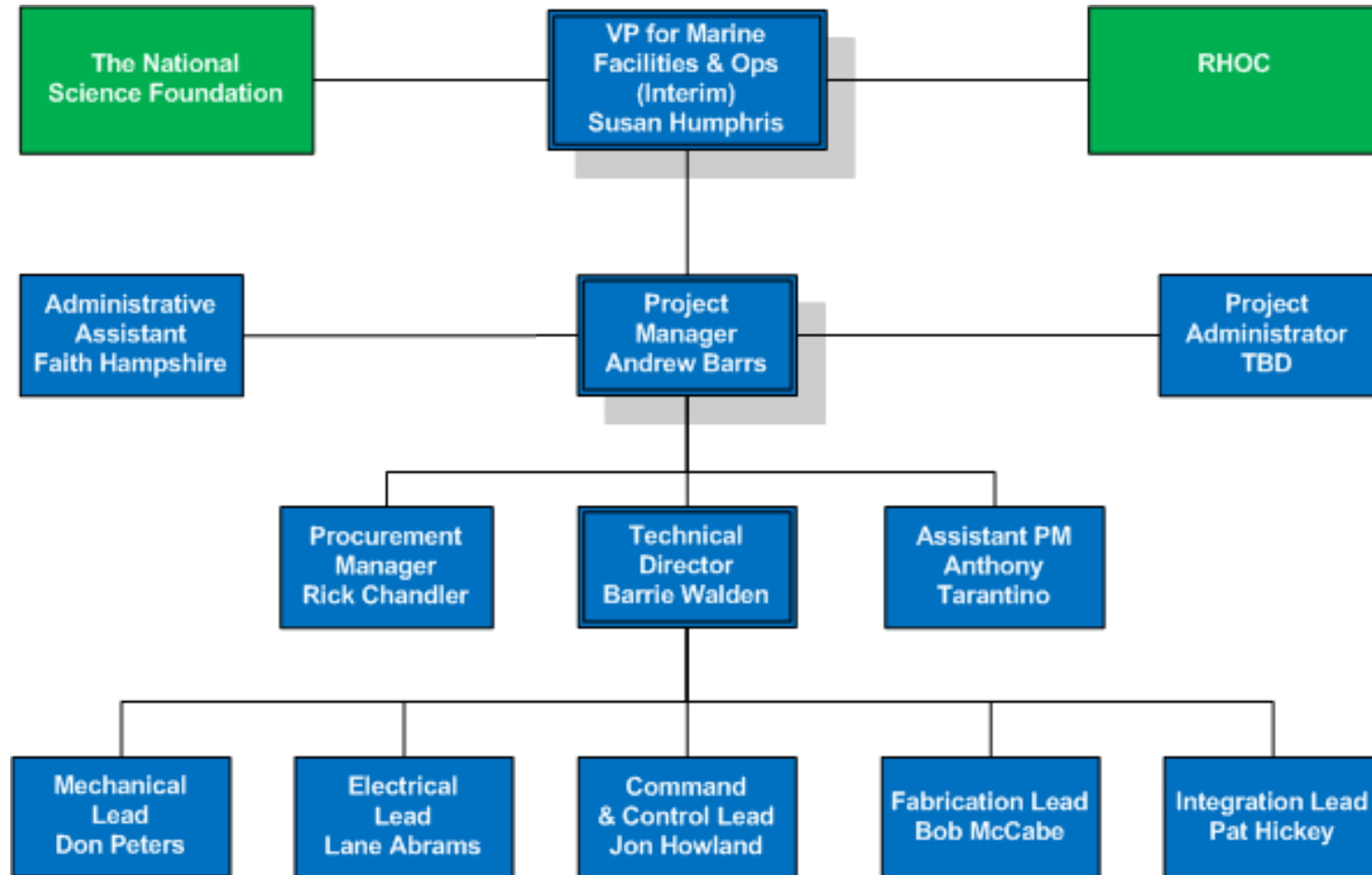



# Alvin Upgrade Project

DESSC  
December 2008

## Project's Goals

<u>RHOV Goals to be Met</u>	<u>Original RHOV</u>	<u>Alvin Upgrade</u>
1.Increased bottom time	Yes	Phase 1
2.Increased battery capacity	Yes	Phase 1
3.Larger personnel sphere	Yes	Phase 1
4.Improved field of view	Yes	Phase 1
5.Improved interior electronics	Yes	Phase 1
6.Automated position keeping	Yes	Phase 1
7.Increased science payload	Yes	Phase 1
8.Improved lighting & video systems	Yes	Phase 1
9.Increased hydraulic plant capacity	Yes	Phase 1
10.Increased thruster horsepower	Yes	Phase 1
11.Improved mid-water research capability	Yes	Phase 1



# Alvin Upgrade Project

## Project's Goals

DESSC  
December 2008

### RHOV Goals to be Met

### Original RHOV

### Alvin Upgrade

12.6,500 meter operating depth	Yes	Phase 2
13.Reduced seabed disturbance	Yes	No
14.Multi-purpose seawater ballast system	Yes	No
15.Elimination of mercury trim system	Yes	No
16.3-D high definition imaging system	Yes	Option
17.Micro fiber high bandwidth communications	Yes	Option



# Alvin Upgrade Project

## Specific Capabilities

DESSC  
December 2008

### Targets

### Alvin

#### Alvin Upgrade

• Maximum Depth	4,500m	6,500m (Ph 2)
• Sphere Volume	144.2 ft <sup>3</sup>	170.8 ft <sup>3</sup>
• Science Payload (Ext)	275 lbs	400 lbs
• Forward Speed (max)	2 kts	2.5 kts.
• Vertical Speed (max)	30 m/min	40 m/min
• Positioning Control	manual	manual + automatic
• Batteries	lead-acid	lithium-ion
• Battery Voltage	120 vdc	240 vdc
• Available Energy	32 kW-hr	80 kW-hr



# Alvin Upgrade Project

## Changes to Mode of Operations

- Minimal changes to daily dive operations
- Minimal changes to R/V Atlantis
  
- Longer bottom times
- Reduced battery maintenance required
- Enhanced Mid Water Column capabilities
  
- Retain one pilot and two science observers
- Retain steel drop weight system
- Retain mercury trim system



# Alvin Upgrade Project

## Risk Mitigation

DESSC  
December 2008

### Technical Risks

- ABS Classification of existing *Alvin* components
- Frame modifications
- Lithium-ion batteries
- Syntactic foam
- Penetrators



# Alvin Upgrade Project

## Risk Mitigation

DESSC  
December 2008

### Schedule Risks

- Sphere delivery
- Battery development
- Syntactic foam
- Penetrators
- MREFC guidelines



# Alvin Upgrade Project Risk Mitigation Schedule

DESSC  
December 2008

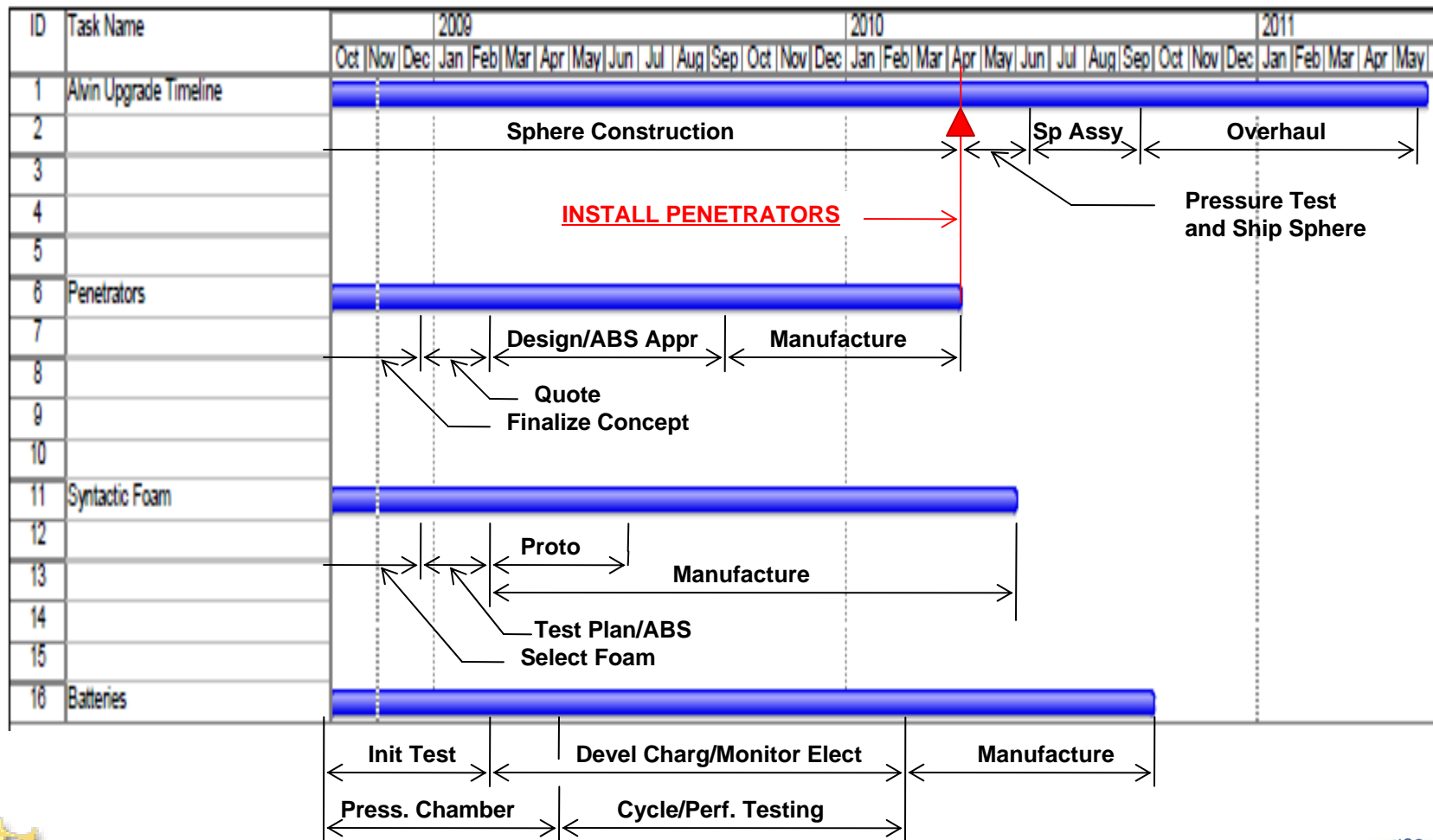

# Alvin Upgrade Project

## Impact to *Alvin's* Operations/Overhaul Schedule

### Current Plan

- Minimal impact as currently planned
- *Alvin's* last overhaul was in 2005/2006
- *Alvin* will continue to operate until its next required overhaul beginning 1 October 2010
- Typical overhaul requires 6 months
- *Alvin Upgrade* integration will coincide with overhaul schedule
- *Alvin Upgrade* will be operational and available for the scientific community by the summer of 2011





# Alvin Upgrade Project

## Status of Sphere Fabrication

DESSC  
December 2008

<b>Forge Disks into Hemispheres</b>	<b>6/08</b>
<b>ABS/SwRI Inspection of Hemispheres</b>	<b>7/08</b>
<b>Heat Treat Hemispheres (Bodycote)</b>	<b>8/08</b>
<b>Rough machine Hemispheres</b>	<b>10/08</b>
<b>Hemisphere Vacuum Anneal (Bodycote)</b>	<b>11/08</b>
Hemisphere Machining	11/08-2/09
Hemisphere Girth Weld	3/09
Insert Welding	4/09-10/09
Post Weld Stress Relief	12/09
Final Assembly	3/10
Hydro Test	6/10
Sphere Complete	7/10



# Alvin Upgrade Project

## Sphere Fabrication

DESSC  
December 2008



Advanced Imaging and Visualization Laboratory/Woods Hole Oceanographic Institution



# Alvin Upgrade Project Timeline

DESSC  
December 2008

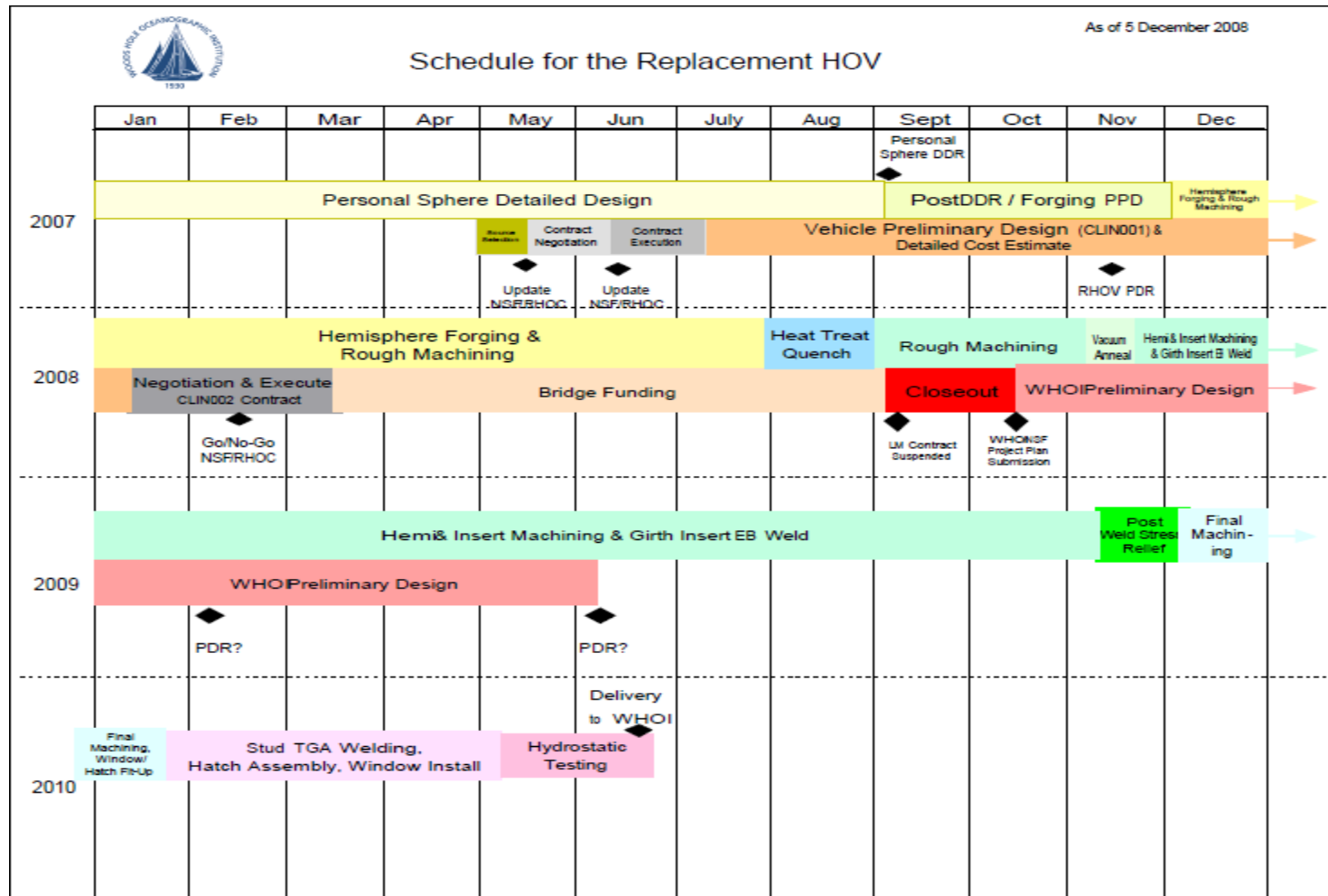

# Alvin Upgrade Project

## Cross Section

DESSC  
December 2008

