

Replacement Human Operated Vehicle (RHOV)

Project Update



Personnel Sphere

Technical Status

- **Titanium 6Al-4V ELI material testing completed.**
- **Successful completion of preliminary design review December 2006.**
- **Detailed design started.**
- **Fabrication started.**

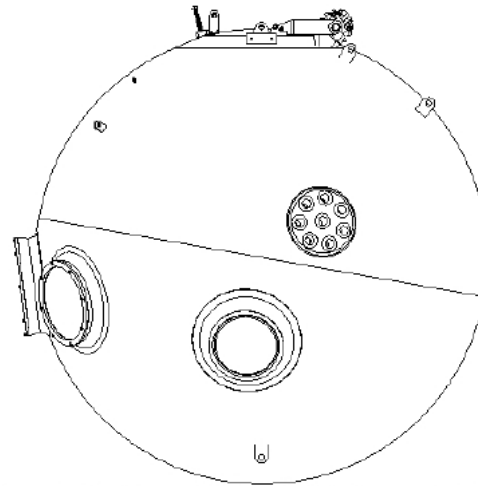

Personnel Sphere

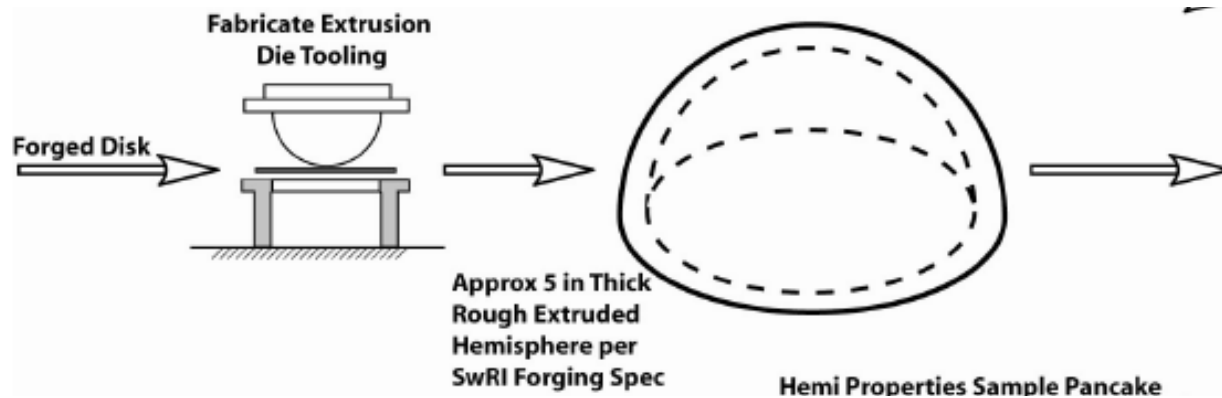
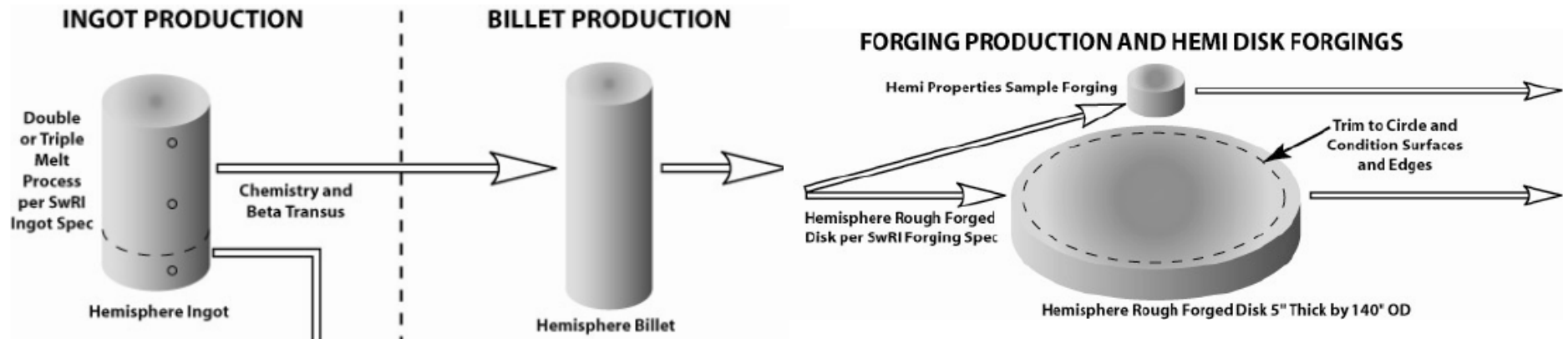

Personnel Sphere



As of 6 February 2007

Schedule for the Replacement HOV Personnel Sphere

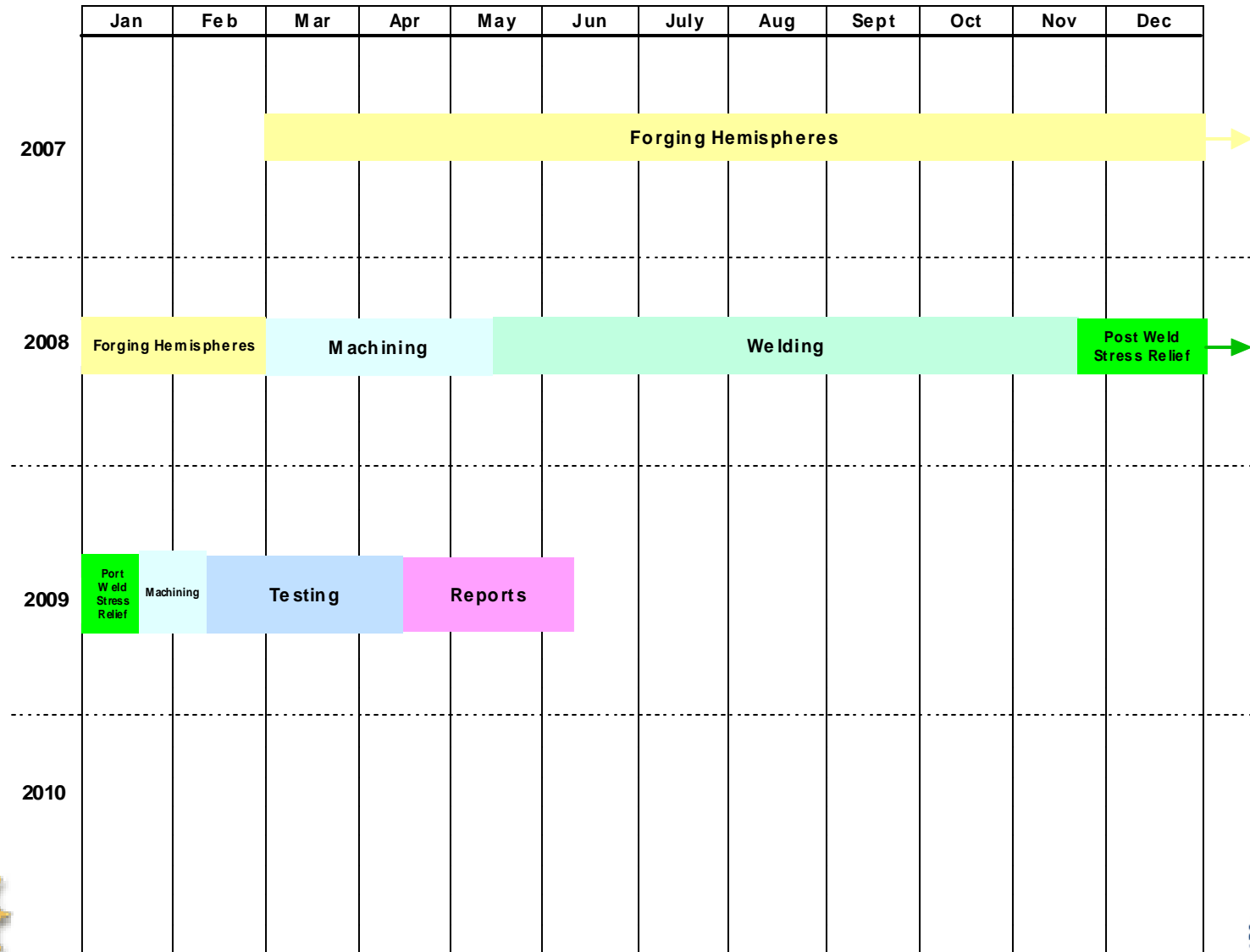

Overview of Original Contracting

- **RFP released on November 2006**
- **Two contract line items (CLINs)**
 - Cost Plus Incentive Fee for Detailed Design
 - Fixed Price Incentive Fee for Construction & Testing
 - RFP required a Not-To-Exceed Target Price
- **RFP sent to seven potential offerors**
 - General Dynamics
 - Northrop Grumman
 - Lockheed Martin
 - Oceaneering
 - OceanWorks
 - Batelle Memorial
 - International Submarine Eng (ISE)
- **Only two proposals received**
 - Cost of proposals significantly higher than budgeted
- **RFP cancelled on 16 Jan 2007**



The Way Ahead

Options to reduce costs

- Loosen/modify technical specifications
- Reduce programmatic requirements
- Shift more work to WHOI
- WHOI managerial costs – savings achieved to date
- Cross-deck more *Alvin* equipment
- Change contract structure/approach



Revised Contracting Strategy

- **Preliminary design and detailed cost estimate – unpriced cost reimbursable**
 - Negotiate the price for detailed design/fab/testing six weeks after completion of PDR.
 - Include clause that allows WHOI to cancel contract based on estimate received after PDR.
 - Collaboration between WHOI and contractor in developing SOW, specs, and cost estimates.
 - The advantage is a clearer understanding by both parties of the requirements.
 - Will reduce risk to contractor and mitigate potential cost overruns.
- **Detailed design and fabrication and testing – cost plus incentive fee**



Vehicle



As of 6 March 2007

Schedule for the Replacement HOV

