

# Serial Communications

Thomas C. Wilson, Jr. • [thomas.wilson@stonybrook.edu](mailto:thomas.wilson@stonybrook.edu)  
Instrument Laboratory • School of Marine and Atmospheric Sciences  
Stony Brook University

RVTEC 2023  
Honolulu HI – v1.1



Stony Brook University  
*School of Marine and  
Atmospheric Sciences*



# Standard Disclaimers

*Unless otherwise noted:*

- Mention of a company in this presentation does not constitute an official endorsement by the State of New York, the State University of New York, or the School of Marine and Atmospheric Sciences.
- The presenter has no ownership interest in any commercial entity mentioned.

## **Special At-Sea Rated “No Chop-Busting” Disclaimers**

- The presenter has never dated anyone connected to any mentioned company, nor is this ever likely. Neither have those folks plied him with baubles, nor trinkets, nor fancy food and drink.

**Anyone who implies otherwise is asking for trouble.**

# TODAY - ASYNCHRONOUS SERIAL

## Serial communication

Transmission of digital data one bit at a time, in sequence.

## Asynchronous communication

Transmission of data without the use of a separate clock or trigger signal. Any timing required to recover data is encoded within the transmission.

### 1) Synchronous Transmission: -

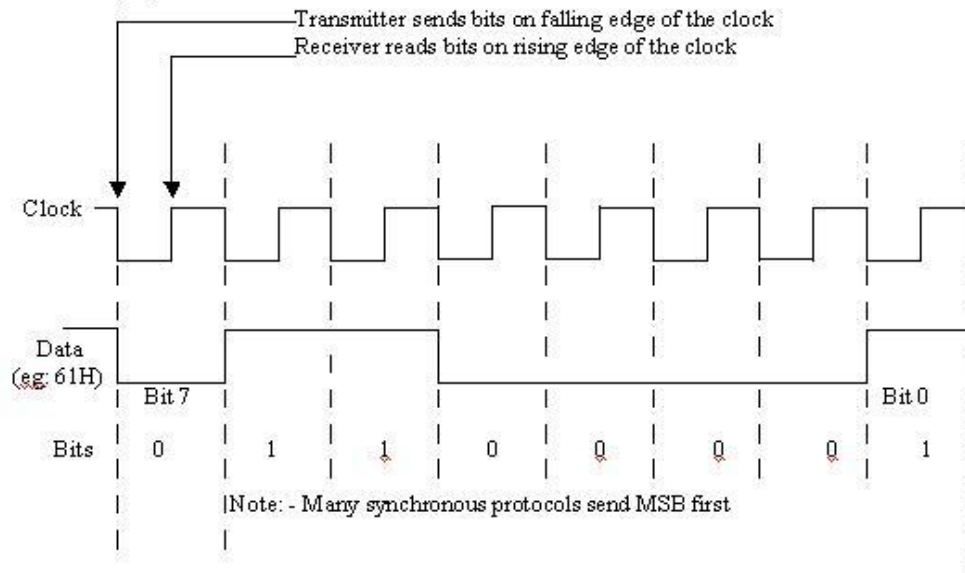

### 2) Asynchronous Transmission: -

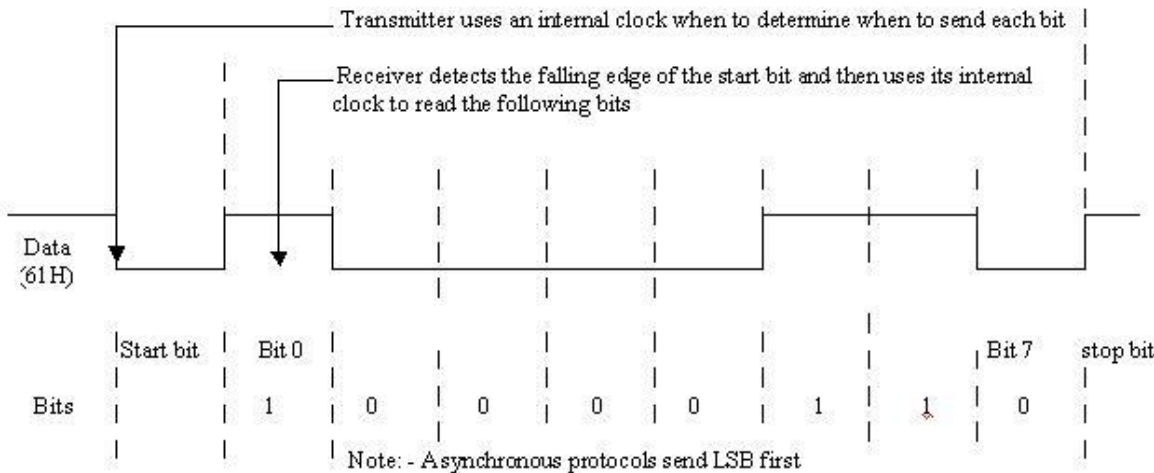

# BITS, BYTES, AND FRAMES

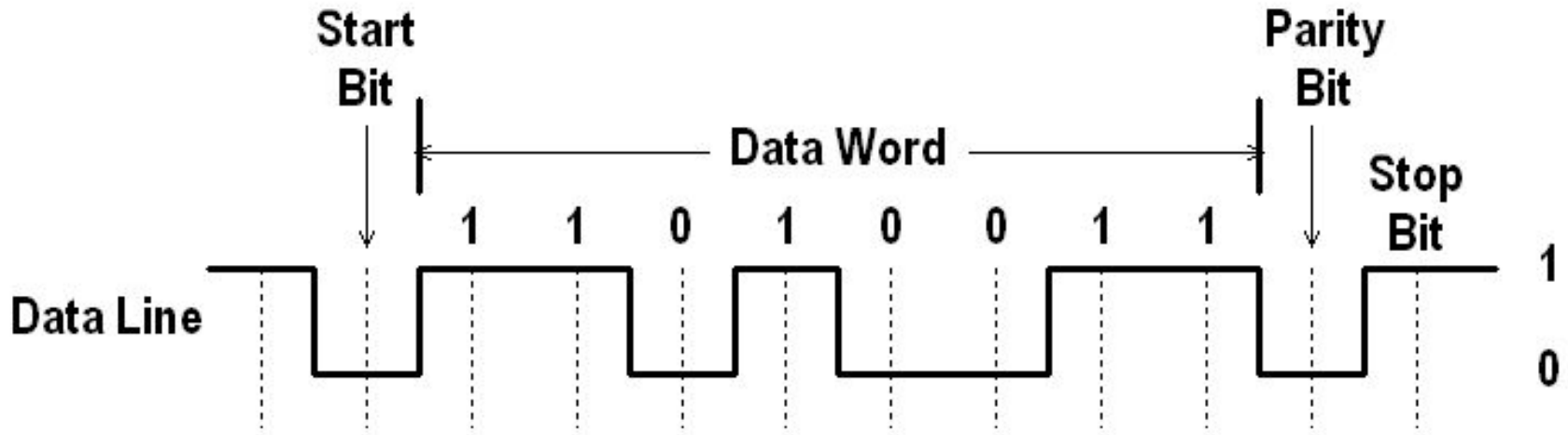

Technically a “frame” but usually referred to as a “character”.

**Mark level** is idle, logic 1s, and stop bit(s).

**Space level** is start bit and logical 0s.

In the example above Mark is high level and Space is low level,  
**but this is not the case for all protocols**

# BITS, BYTES, AND FRAMES

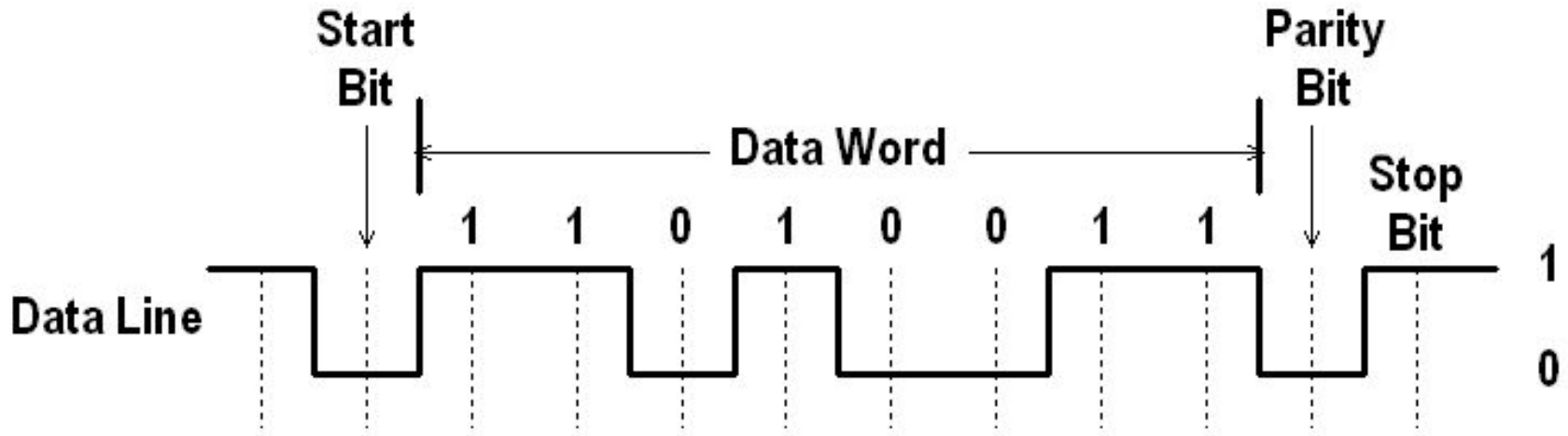

**Start bit** signals beginning of frame/character.

**Data bits:** commonly 8, sometimes 7, almost never others.

- The least significant bit is sent first.
- Character represented above is 11001011 = ASCII 203

# BITS, BYTES, AND FRAMES

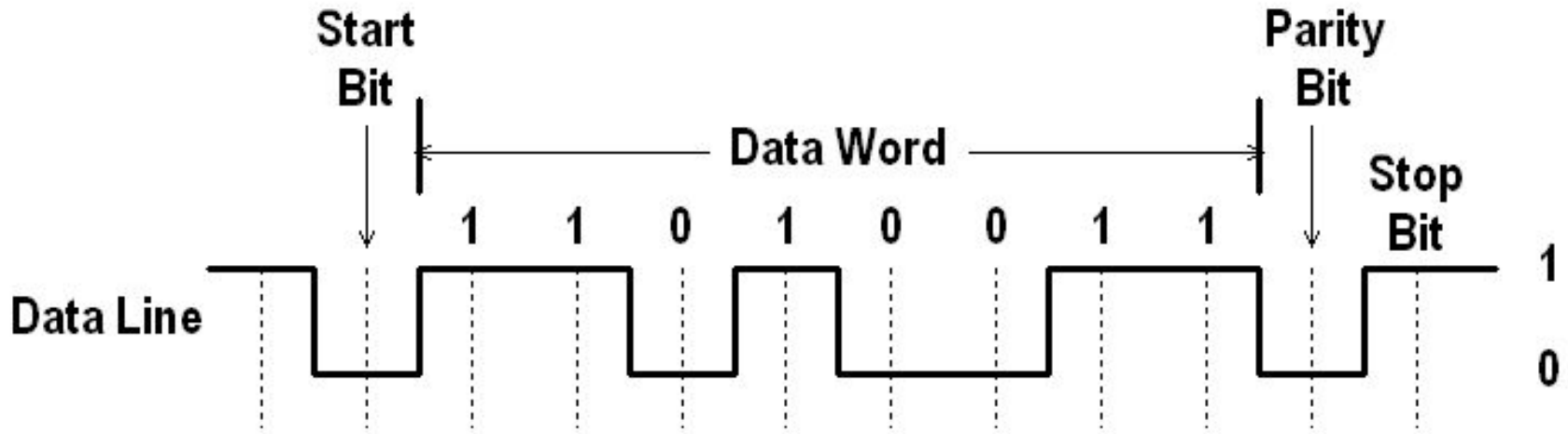

**Parity bit** can be none=nonexistent (most common), mark, space; or even/odd to detect transmission errors.

- In odd or even parity, parity bit is set so number of 1s in data word plus parity bit is even or odd. Five 1s in data byte above, parity bit is 0, so parity above is odd.

**Stop bit:** most commonly 1 stop bit, rarely 2. Can be followed immediately by start bit of next frame/character or just stay at Mark level indefinitely.

# BAUD

Named for Emelie Baudot, who invented a 5 bit code for telegraphy that supplanted Morse Code.

Baud = symbols per second. Equals bits per second in serial comms but not where tech encodes multiple bits per symbol (such as modems).

Common baud rates today:  
4800, 9600, 19200, 38400

Archaic: 600, 1200, 2400

Hopefully extinct: 110, 300

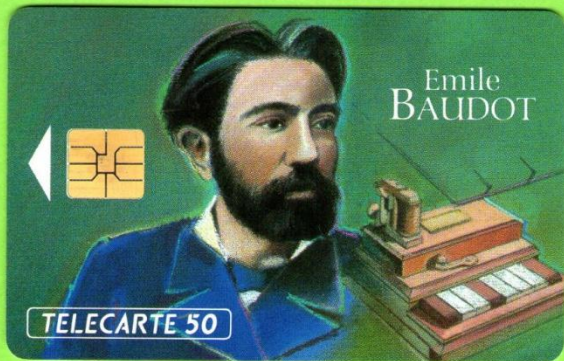

	1	2	3	4	5		1	2	3	4	5
A		•	•			Q	1	•	•	•	•
B	?	•			•	R	4		•		•
C	(		•	•	•	S	'	•		•	
D	²	•			•	T	5				•
E	3	•				U	7	•	•	•	
F	1/	•		•	•	V	)		•	•	•
G	³/		•		•	W	2	•			•
H	⁵/			•	•	X	£	•		•	•
I	8		•	•		Y	6	•		•	•
J	7/	•	•		•	Z	.	•			•
K	⁹/	•	•	•	•	FIG SPACE	FIG SPACE	•	•		•
L	/		•		•	LTR SPACE	LTR SPACE			•	
M	'		•	•	•	LINE PAGE	LINE PAGE				•
N	-		•	•		⌘	⌘	•	•	•	•
O	9			•	•	COL	COL		•		
P	0		•	•							

#12345 gives invisible correction on page printers & ⌘ on slip printers.

# PUTTING IT ALL TOGETHER

Common shorthand for serial characteristics is:

**BAUD RATE + PARITY + DATA + STOP**  
(sometimes baud + data + parity + stop)

19200N81 = 19200 baud, no parity, 8 data, 1 stop.

9600E71 = 9600 baud, even parity, 7 data, 1 stop.

No parity is more common but some manufacturers do use parity. Seabird commonly uses even parity, for example in SBE19 CT recorder.

**Transmitter and receiver baud rates, parity, data bits, and stop bits MUST match!**



# BREAKS and CHECKSUMS

**BREAK** = space level for more than one character length. Term from current loop telegraphy when a physical break in the wire caused this condition. Now often used as an attention signal (one example, to wake up RDI ADCPs).

**CHECKSUM** = a small sized datum (usually a single byte) calculated from a line or block of data, then appended and transmitted with that data. The receiving process calculates the checksum of the received data and compares it with the received checksum to verify data integrity.

Checksums add data integrity verification. Useful in high noise environments and for critical safety applications such as motor or winch control or navigation data -

**If you do something with the information.**

# UARTs Hard and Soft

## Universal Asynchronous Receiver Transmitter



8250 UART used in original IBM-PC. 1488 driver and 1489 receiver chips (translates between logic levels and RS232 voltage levels) visible at top.

**Hardware UART:** specialized hardware, once separate chips, now commonly integrated into microprocessors.

**Software UART:** Built into compilers or firmware. Sends/receives serial data on a general purpose digital I/O line as a background task. Usually not as capable as a hardware UART but often good enough.

# Logic level – CMOS/TTL

Voltage levels at native logic level of device  
Most common values are 5VDC and 3.3VDC

Single ended signal referenced to common ground.

**Mark level [idle, logic 1s, and stop bit(s)] at logic high.  
Space level (start bit and logical 0s) at logic low.**

Logic level is low power and sensitive. Unprotected, unbuffered, often connected directly to microprocessor.

**USE WITHIN A DEVICE ONLY - TOTALLY UNSUITABLE  
FOR DEVICE TO DEVICE COMMUNICATION**



## **RS232 – The 800 pound gorilla.**

Likely to be 90% of your serial interfacing.

Single ended signal  
referenced to common ground.

**Mark level [idle, logic 1s, and stop bit(s)] = -3 to -25 V**

**Space level (start bit and logical 0s) = +3 to +25 V**

Most commonly +/- 7 to +/-15 volts.

**Logic inverted from CMOS/TTL.**

Surge and static discharge protected.

The RS232 specification states that any line can be shorted to ground, mark level, space level, or any other line indefinitely without damage.

**This does not mean it's a good idea,  
particularly with cheap implementations.**

Official length limit 50 feet-

*AKA the most ignored specification in electronics.*

# STANDARD RS232 PINOUTS

## Looking Into the DTE Device Connector

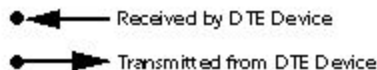
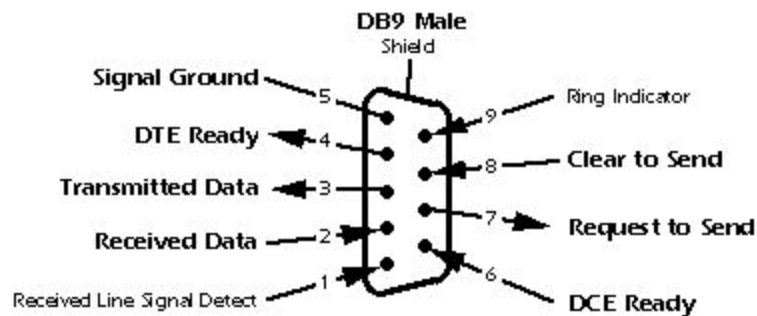
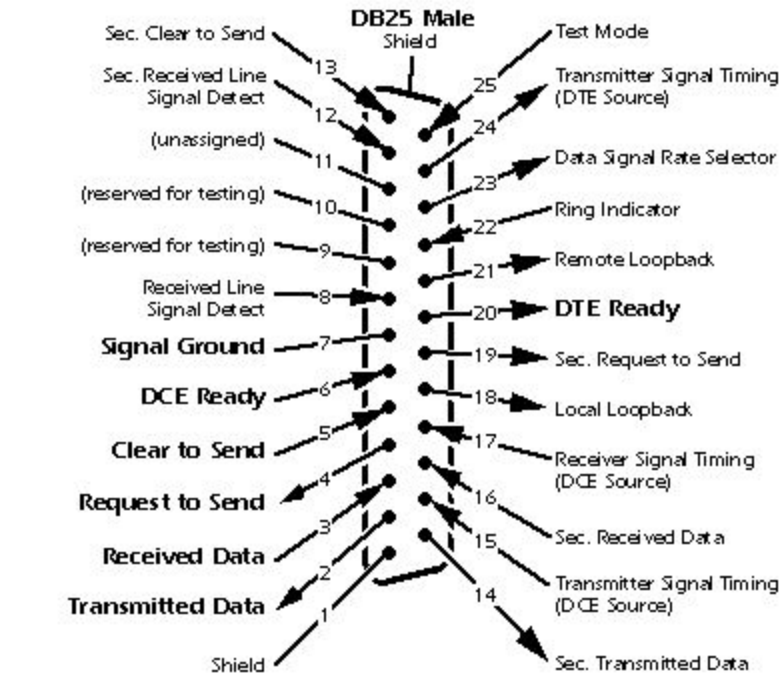

## Standard conventions:

**DTE** (data terminal equipment).

- Computer side.
- Male connector.

**DCE** (data communications equipment).

- Peripheral side.
- Female connector.

Signals defined in relation to DTE side: transmitted data means transmitted from the DTE device (computer).

## 9 and 25 Pin Connectors



Original standard connector had 25 contacts  
**DB25M** (male = contacts are pins)  
**DB25F** (female = contacts are sockets)

Many signals on the 25 pin connector are obsolete so 9 pin standard was introduced and is now much more common.

The new connector is an “E” shell size so official names are DE9M and DE9F



BUT common usage is  
**DB9M** and **DB9F**

*Examples following  
use 9 pin connector numbers.*

# SOFTWARE HANDSHAKING

Receiver transmits a special character or sequence to control transmission flow. Two examples:

- Specialized programs (e.g. Seabird CT recorder upload), will send a command to receive a block of data, examine it for integrity, then either request the next block or retransmission.
- XON/XOFF protocol (mostly obsolete): receiver sends XON to transmitter to initiate or resume transmission, XOFF to transmitter to suspend transmission.

# HARDWARE HANDSHAKING I - WHAT?

Transmitter and receiver set state of logic lines for flow control.

- DTE transmits: Data Terminal Ready (pin 4) and Request to Send (pin 7).
- DCE transmits: Data Set Ready (pin 6), Clear To Send (pin 8), Data Carrier Detect (pin 1), and Ring Indicator (pin 9).
- Handshake off state is -3 to -25 V.
- Handshake on state is +3 to +25V.



# HARDWARE HANDSHAKING II – HOW?

- DCD historically indicates modem carrier established, RI indicates incoming call.

Ideal sequence of hardware-mediated data flow.

- DTE sets RTS to ON.
- DCE responds by setting CTS to ON.
- DTE sets DTR to ON and transmits data. DCE sets CTS off if needed to throttle transmission.
- At conclusion of transmission DTE sets DTR and RTS to OFF.
- DCE responds by setting CTS to OFF.

# HARDWARE HANDSHAKING III – DO NOT FUGGEDABOUTIT !

Most computers are so fast nowadays they don't need handshaking – BUT interface hardware or applications software may or may not ignore handshaking lines, so you shouldn't either.

- If not needed, hardware handshake should be disabled by jumping DTR to DSR (pins 4-6) and RTS to CTS (pins 7-8) at each connector.

- Optionally, CD (pin 1) can also be jumpered to pins 4 and 6. This forces the CD input high on DTE side (almost certainly unnecessary) but also connects CD and DSR outputs together on DCE side (supposed to be OK if standards followed). “Choose Door #1 or Door #2...”

## **Two useful modern applications for handshake lines:**

- Some Serial to Ethernet systems use DCD to indicate an active network connection.

- Arduino compiler uses DTR or RTS to reset processor when reprogramming.

# COMMON RS232 CABLES - I

**It's not always necessary to connect all nine wires  
(let alone all 25 wires)**

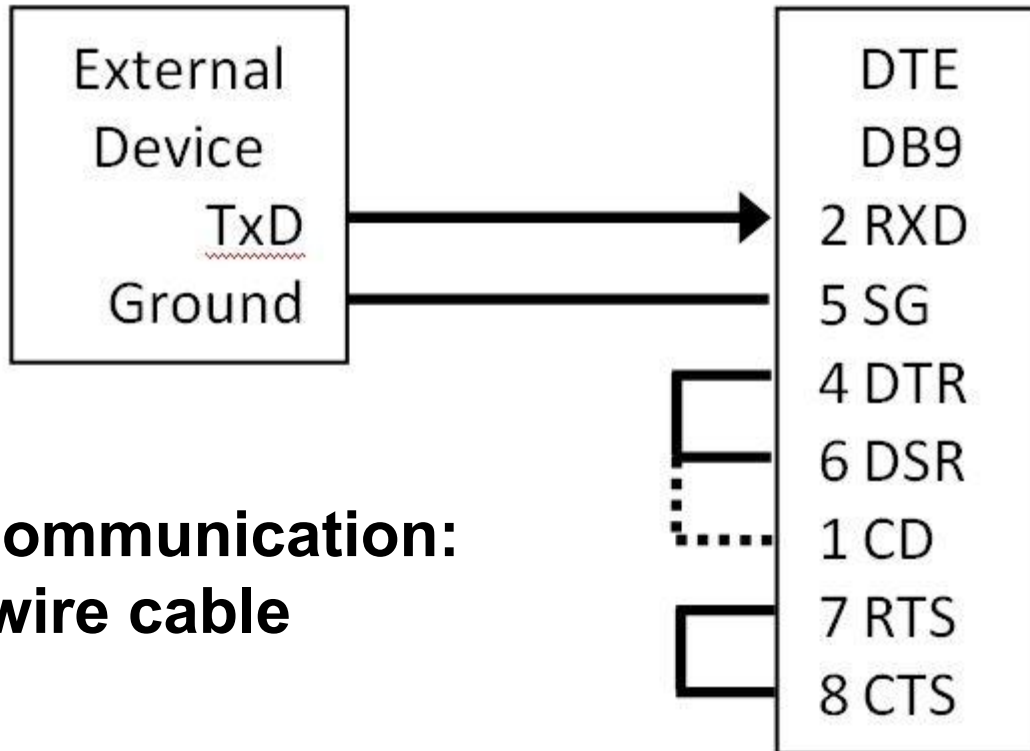

**One way communication:  
two wire cable**

Optional jumper of pin 4-6 to pin 1 shown. Use if desired here and where other 4-6 jumpers are shown in following examples.

# COMMON RS232 CABLES - II

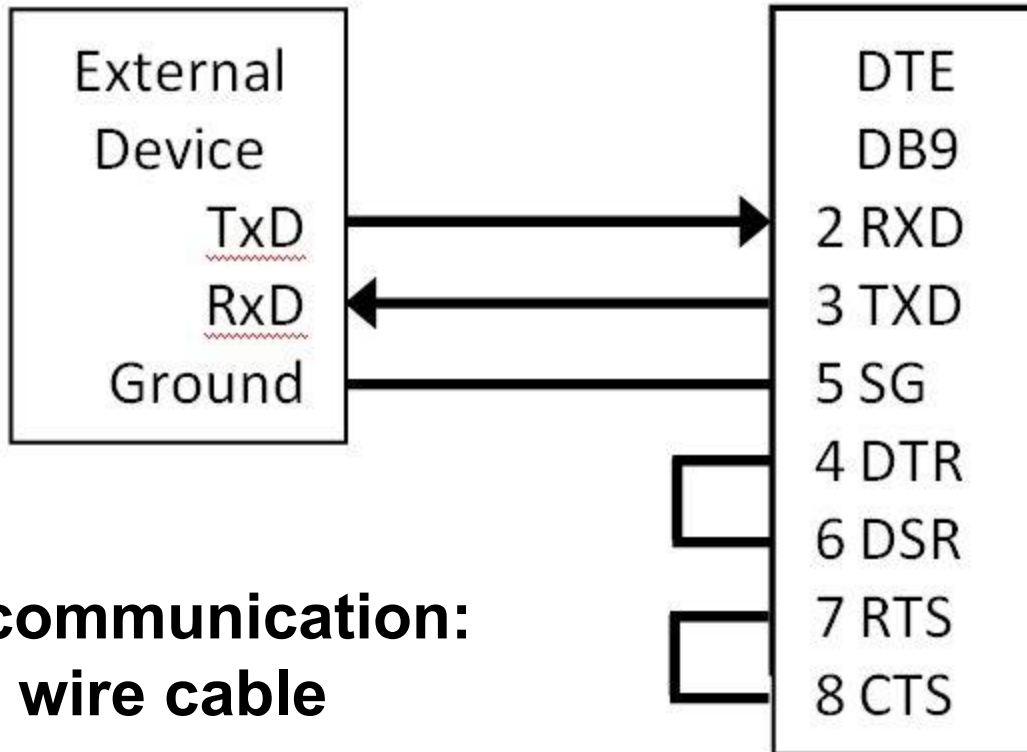

**Two way communication:  
three wire cable**

# COMMON RS232 CABLES - III

**Null Modem cable - “when straight through won’t do”**

**Seven wire**

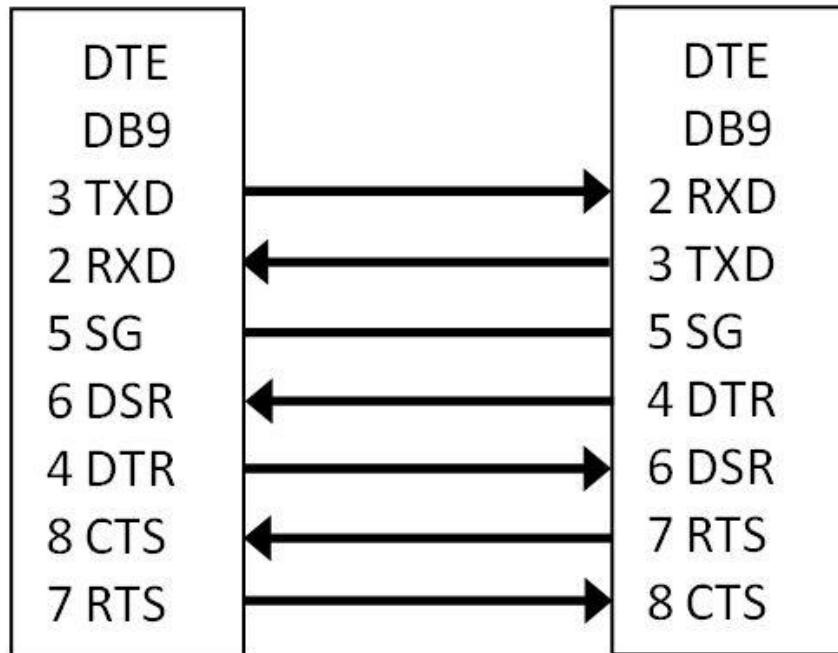

**Three Wire**

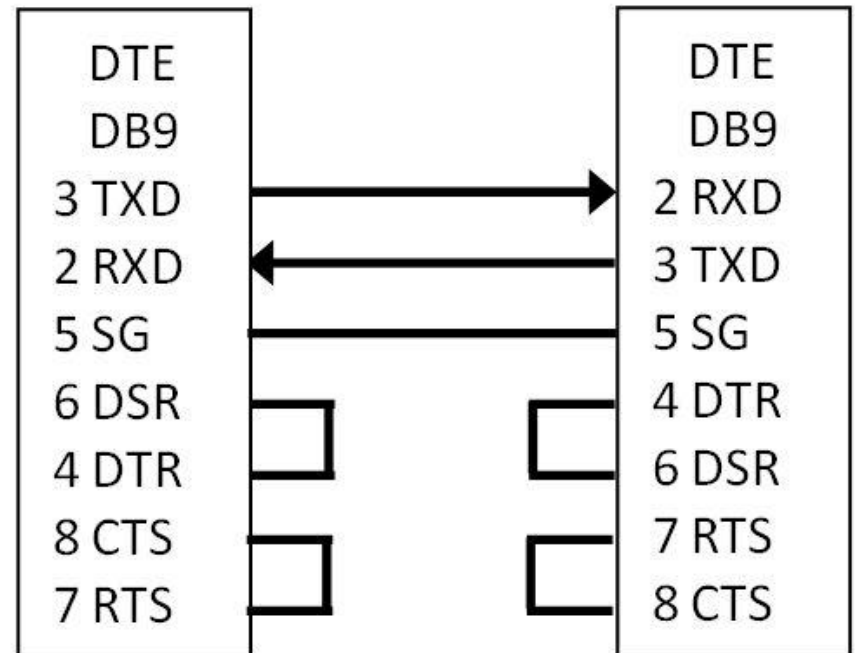

DCE to DCE null modem identical wiring,  
just reversed signal definitions

# RS422 (is your friend)

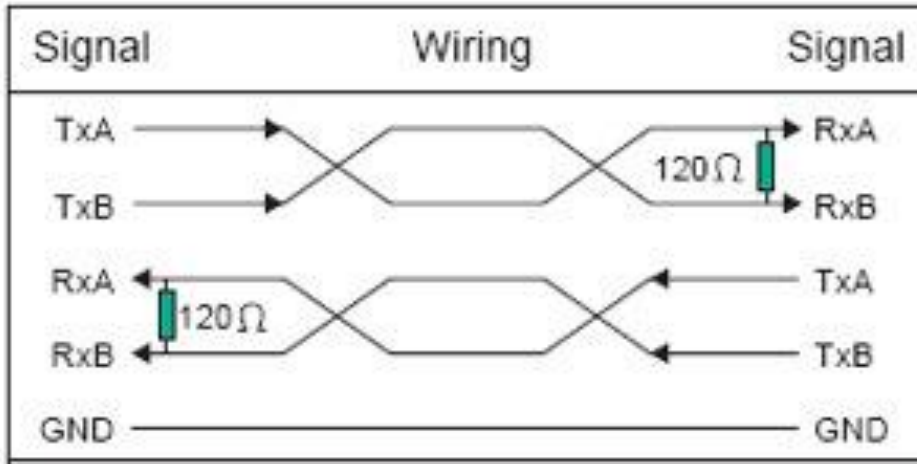

Differential signal  
over twisted pair.  
Signal levels 0 and 5 volts.

**B>A = Mark level [idle, logic 1s, and stop bit(s)] .**

**A>B = Space level (start bit and logical 0s)**

One transmitter can drive up to 10 receivers at up to 10 Mb/s.  
Range limit 1200 meters at 90 kb/sec over 24 AWG solid twisted pair (telephone wire). RS232 to RS422 conversion is just hardware, so it's ideal for extending RS232. Add a power line to operate bottom mounted ADCPs or wave gauges over 1000m of 7-conductor Rochester double armored well logging cable.

# NMEA 0183

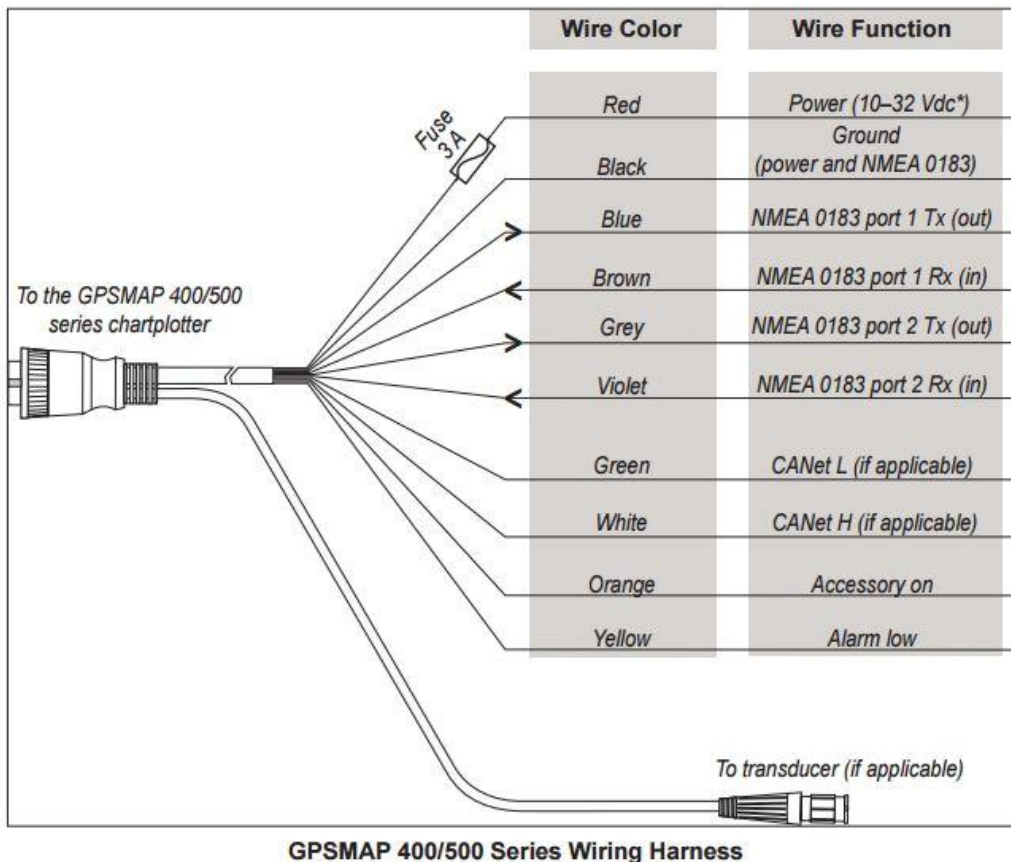

Communications standard for marine electronics – GPS, sounders, autopilots.

NMEA 0183 v1 used single ended +/-12-15 volt signal levels.

NMEA 0183 v2 and higher uses RS422 levels. Many manufacturers don't actually implement differential output (see Garmin wiring at left).

It is possible to connect NMEA 0183 directly to RS232. Often works but 0183 voltage output does not actually meet RS232 input specification. Unterminated NMEA- input may prevent commands being recognized – connect to ground!

# RS485 (is sometimes your friend)

Differential signal levels like RS422 **BUT...**

**1 Master and up to 31 slaves transmit and receive on a single pair of wires.**

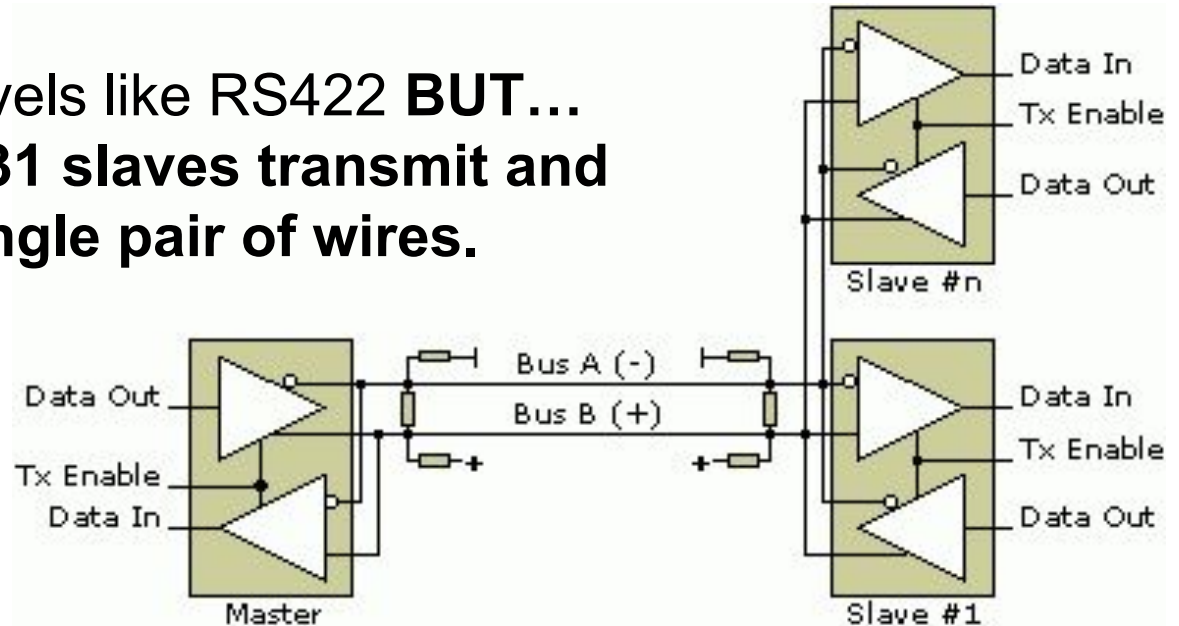

Very much like communications using 2 way radio. Master typically sends commands to one or all slaves, slaves take action and may respond, but only one device can transmit at a time. Many things can and do go wrong.

Use when necessary for gear that uses RS485 only or situations where using more than two conductors is impractical.



# ADAPTERS & HARDWARE

## USB to RS232

Serial ports disappearing from PCs  
Expansion cards only work on desktops &  
complex to install and configure  
USB to RS232 works well on any PC.

Universal Windows support  
Wide Linux support

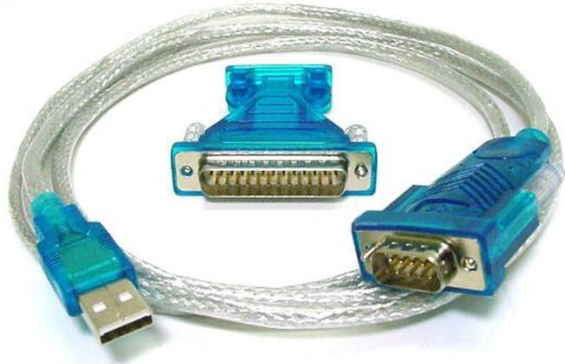

Single port – wide availability



Startech eight port



Edgeport eight port

# RS232 to RS422



**B&B Electronics**  
**422CON**  
Now Advantech  
**BB-422LCOR**

# Logic level to RS485

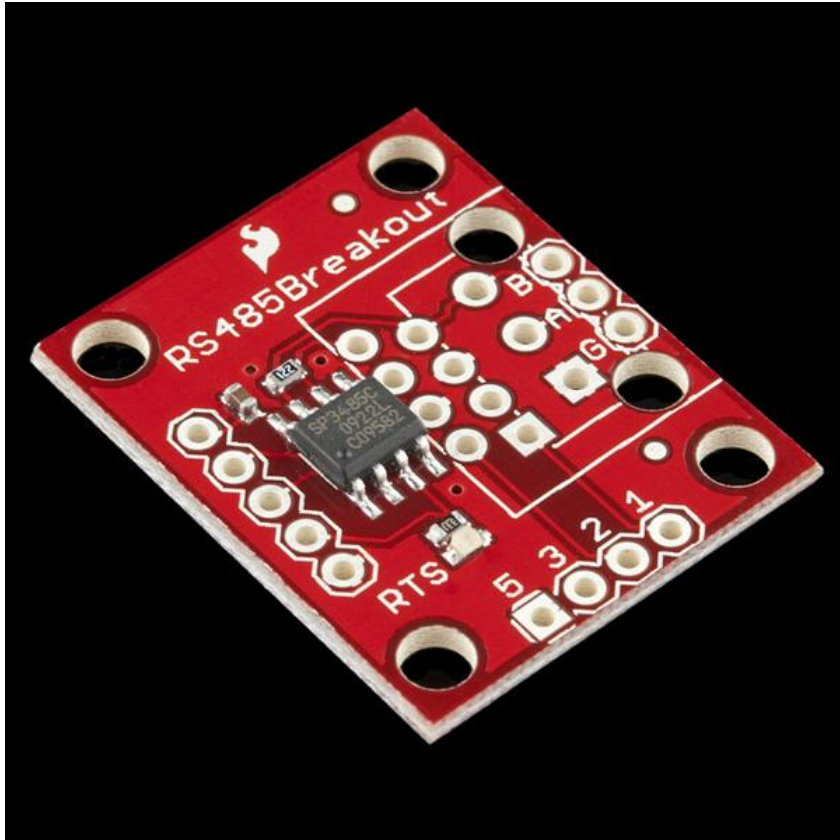

**Sparkfun SP-3485**  
RS485 breakout board

# Logic Level to USB

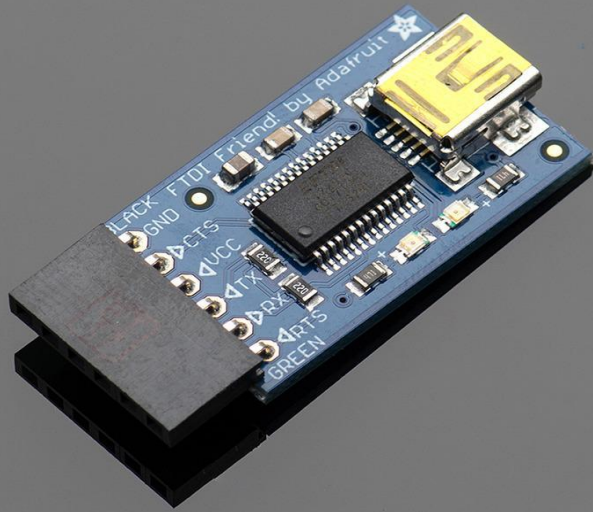

Adafruit FTDI Friend

Selectable 5 or 3.3 volts

Can attach  
male or female adapter

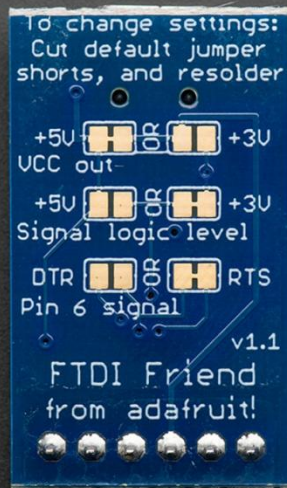

# Logic Level to RS232

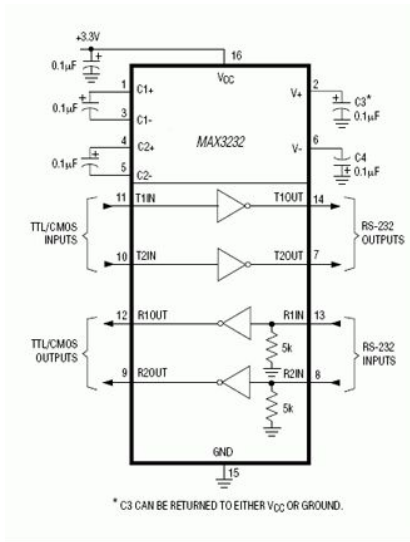

My personal favorite chip:

Maxim MAX3232

True RS232 levels

15kV ESD protection

5 or 3.3 V operation

Low idle power

Small capacitors:

0.1µF to 0.47µF

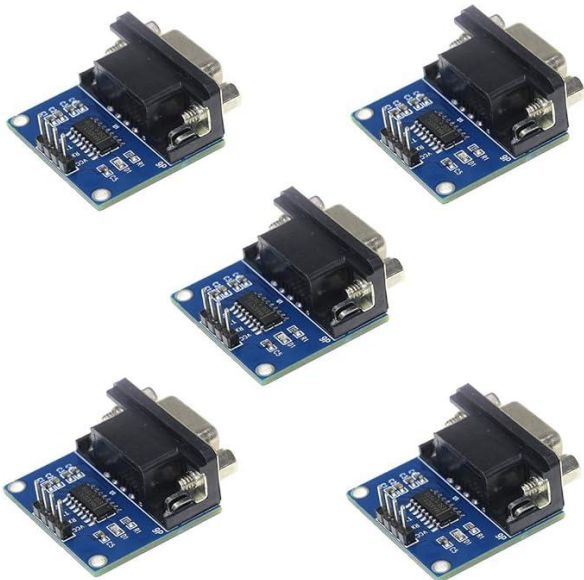

Available as boards on Amazon

# Waterproof RS232 Data Logger

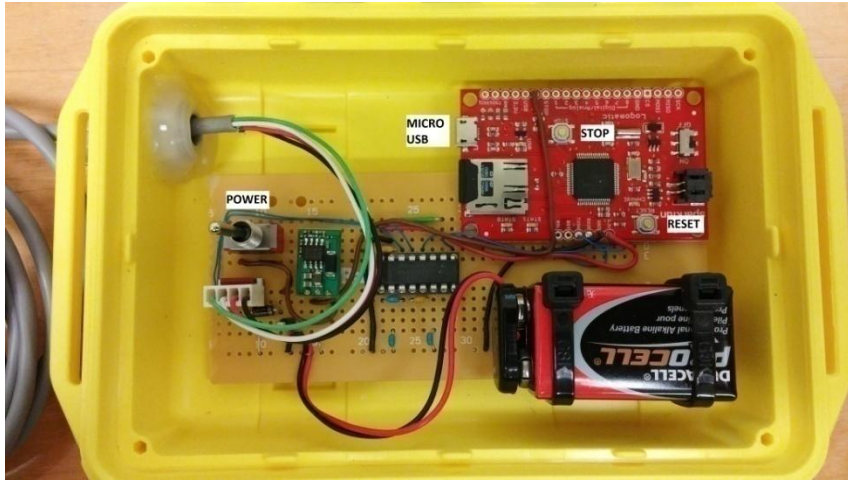

Sparkfun Logomatic 2  
Serial SD Datalogger  
(can also can log analog signals)

Max3232 RS232 chip

Underwater Kinetics Ultrabox  
(used to be) rated to 5 meters immersion  
better than small Pelican cases

Runs on external power  
or several hours  
on internal 9V battery

Log cruise track and water depth  
from Garmin GPSMAP 541  
on 19 foot open boat

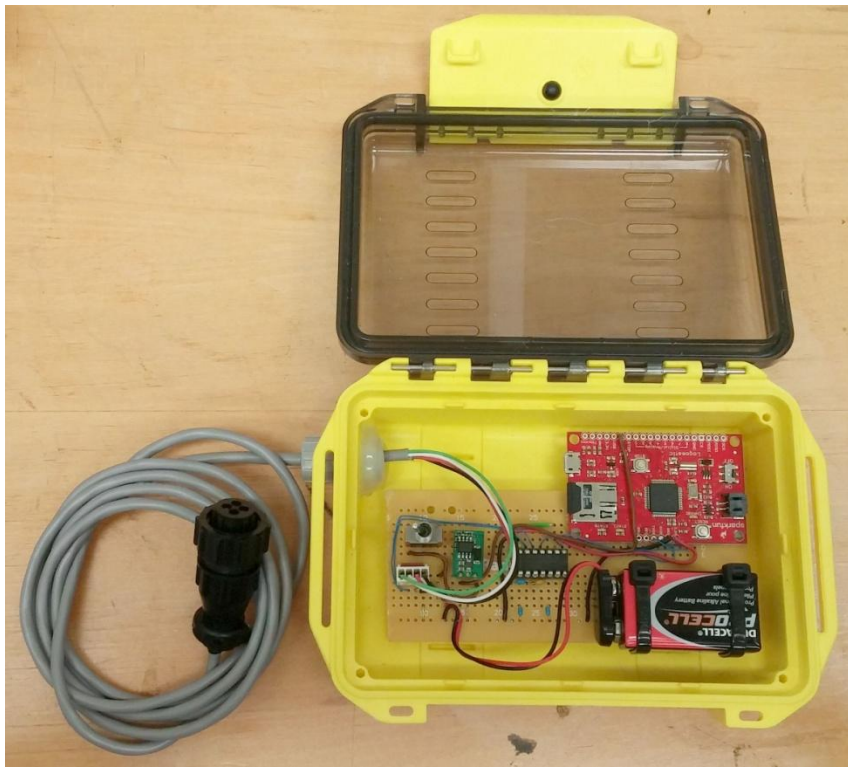

# Surge Protectors and Isolators



Surge protectors provide semiconductor, MOV, and/or gas tube protection for lines to ground.

Optoisolators provide surge, spike, and ground loop protection.

Available for RS232, RS422, and RS485.

Indicated for long runs, outside runs, or for extra protection of critical equipment.

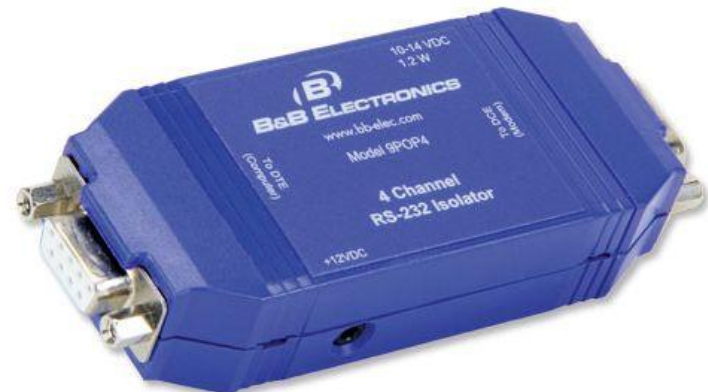
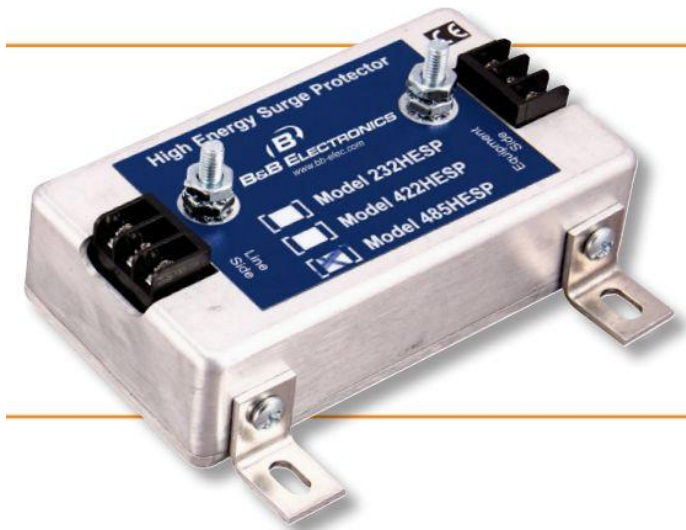

# Roll Your Own Surge Protection

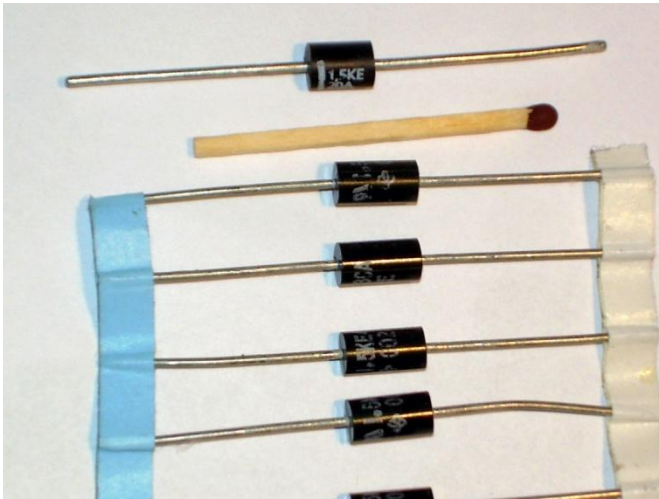

TransZorb Transient Voltage Suppressors

Basically giant zener diodes.  
Connect one lead to signal line,  
other lead to good ground.  
Unidirectional for DC signals. Bidirectional  
(2 devices back to back in same package)  
for bipolar signals – e.g. RS232

Extreme protection with fuses, gas discharge tubes, inductors, and avalanche diodes (e.g. TransZorbs). *At this point you probably should buy a commercial device.*

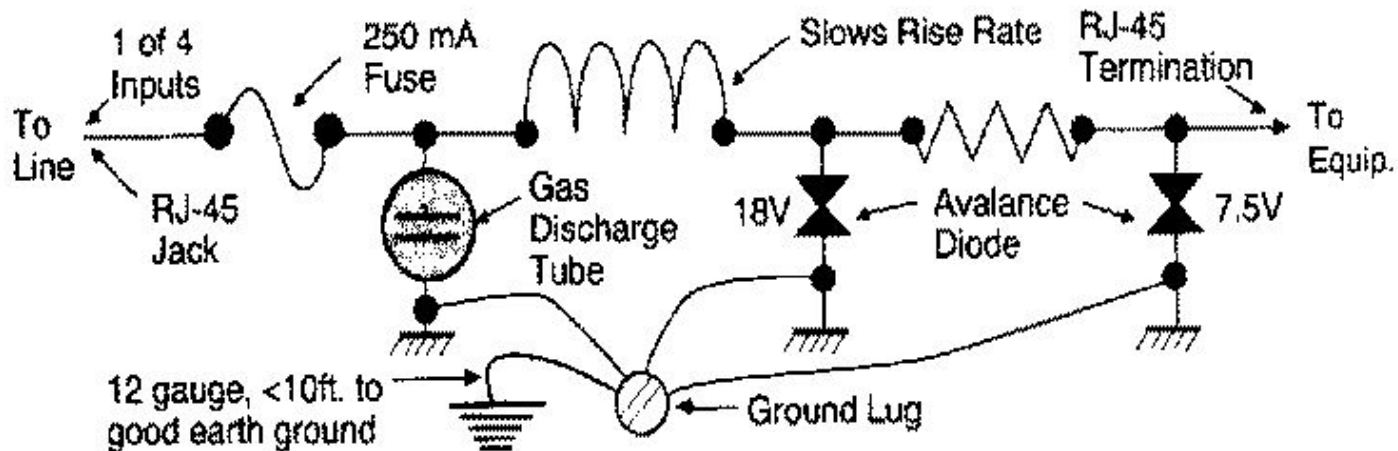



# Serial to Ethernet

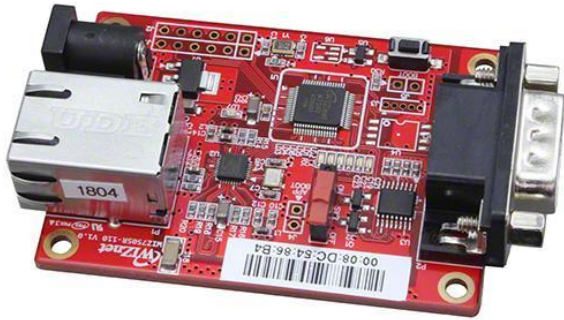

**WIZNET WIZ750SR-110**  
Single RS232I to Ethernet  
300 to 230400 baud  
Comes with VSP (virtual  
serial port) software)

**WAVESHARE**  
**Serial Device Server**  
Ethernet to RS232/422/485  
PoE or 6-36VDC  
Surge protection  
DIN rail mount

# Serial to Bluetooth

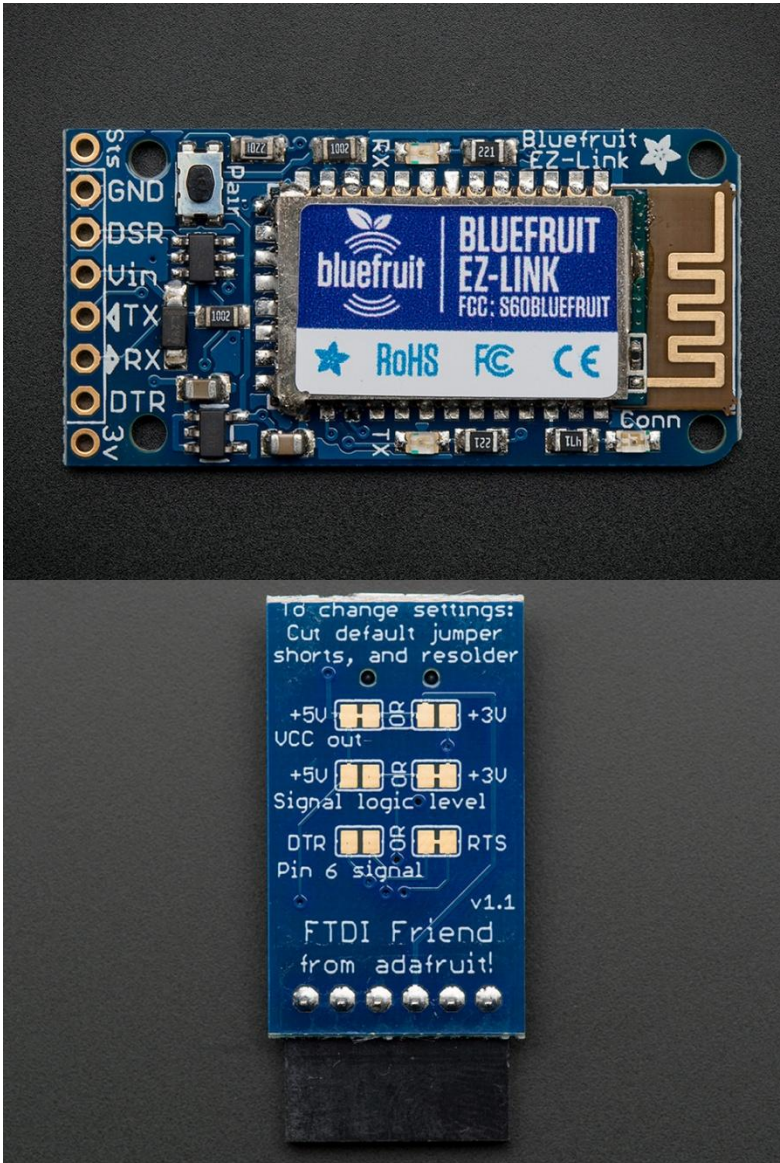

## Adafruit BlueFruit EZ-Link

Bluetooth to logic level  
5 or 3 volt operation

Appears as serial port on PC

Can program Arduino over the air,  
should be able to command devices  
or offload data through a nonmetallic  
pressure case or waterproof box.

# Fiber Optic Converters



Essentially complete protection against surges, spikes, and ground loops.

A little pricey - but maybe worth the money to protect servers from lightning strikes on masthead instruments.

Range hundreds to thousands of meters, extend indefinitely with repeaters.

# HARDWARE TOOLS

## Serial Monitors and Breakout Boxes

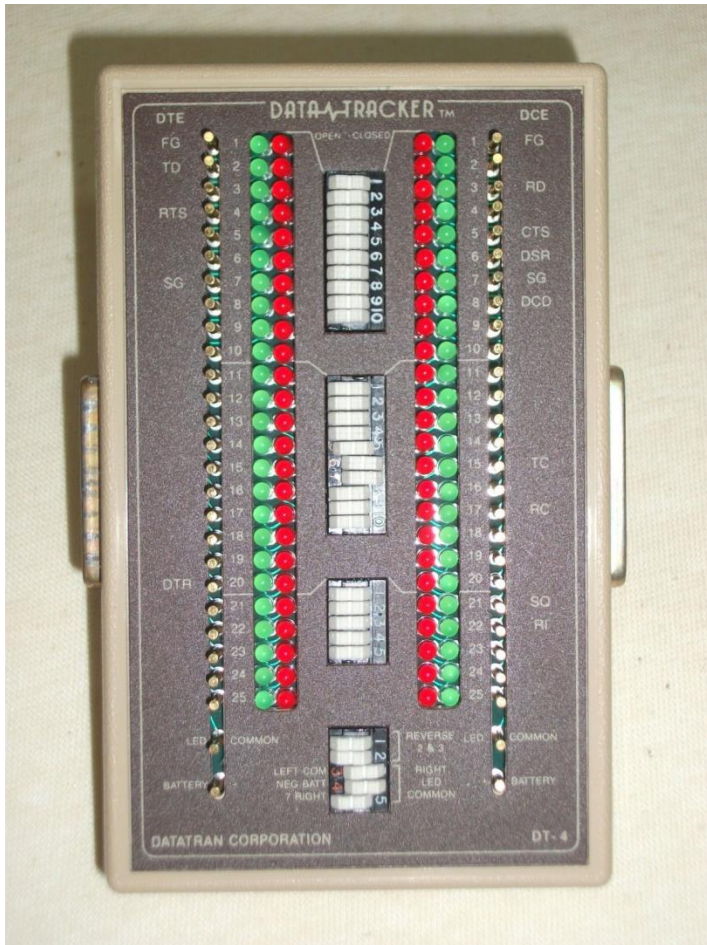

STRAIGHT OUTTA 1986:  
Datatran Data Tracker DT-4  
2 batteries, 30 switches,  
54 contact points, 100 LEDs.



Radio Shack  
Mini Tester -  
of course they don't  
sell these anymore

Happily, Startech.com  
does sell exact same  
thing – Startech MT25



Caution: these are all port powered  
and may break a marginal interface-  
**which should be your cue  
to redesign that interface**

# Gender changers, 9 to 25 & null modem adapters

ADVANCE



Standard



Mini



Null  
modem



# Homebrew Adapters – Clips to DB9F

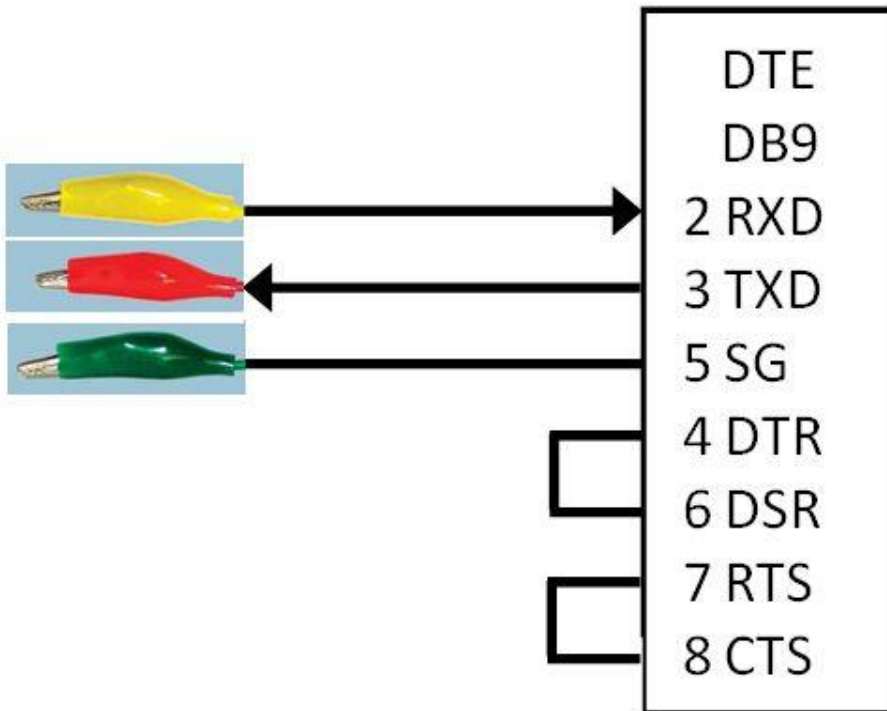

Trace a signal

Scope a signal

# Eavesdropping Adapter

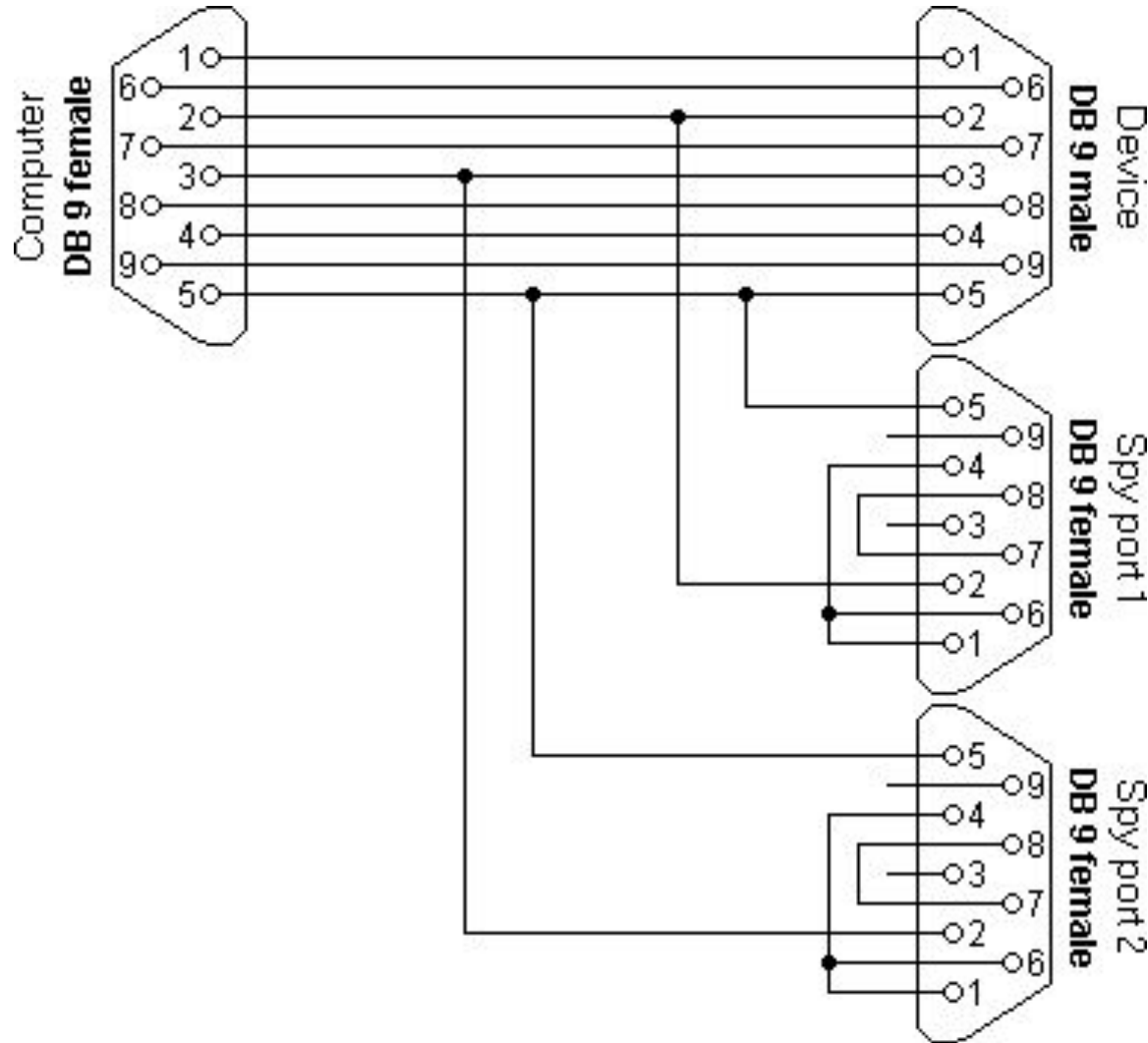

“Wedges” into an RS232 line.

Each “spy port” taps one transmit line.

Two RS232 ports on a diagnostic computer can monitor both sides of interchange.

Also good with DB9 to gator clip adapters for oscilloscope connection.

# Loopback Plug

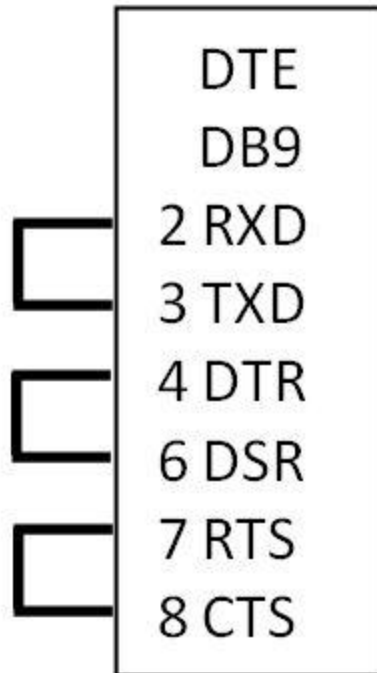

Loops data  
on transmit line  
back to receive line.

Doubles wire length –  
one test of how robust  
your signal is.



# WINDOWS SOFTWARE TOOLS



Anzio Lite – low cost commercial software.



TeraTerm Pro – freeware.

# Stuff You Supposedly Shouldn't Do

(that sometimes works)



## Extra long RS232 lines Passive RS232 splitters

“Get away with it” by using robust RS232 transceivers, quality cable, lower baud rates, RS232 boosters, and/or routing to avoid electrical interference.

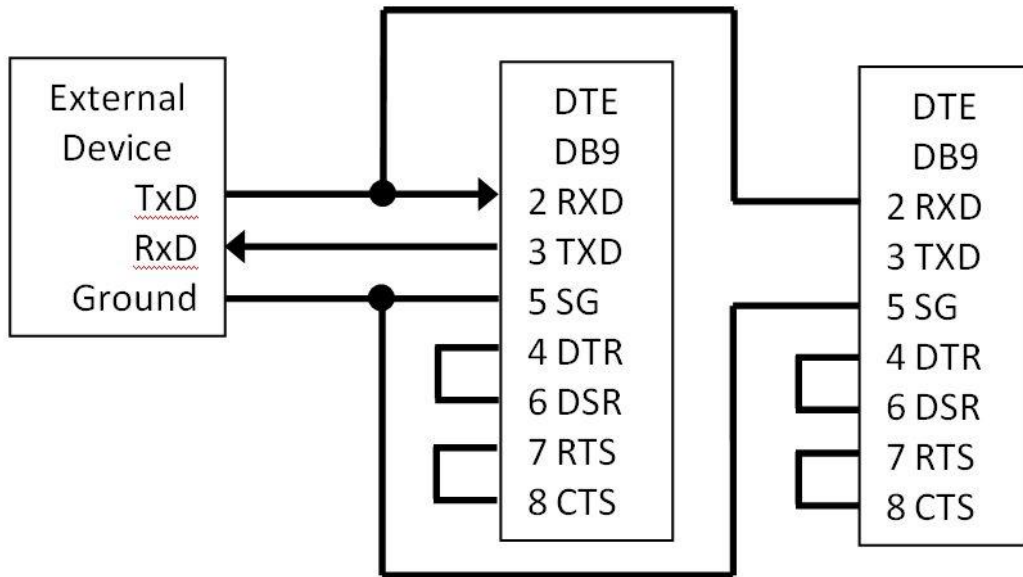

(or use active splitters, or RS422 that allows up to 10 receivers per transmitter AND hundreds of meters of transmit distance.)

# Stuff That Supposedly Should Work (but often doesn't)

TABLE 1 EIA RS-232 SPECIFICATION SUMMARY

Parameter	Conditions	Min	Max	Units
Driver Output Voltage Open Circuit			25	V
Driver Output Voltage Range	$3\text{ k}\Omega \leq R_L \leq 7\text{ k}\Omega$	5	15	V
Driver Output Resistance Power Off	$-2\text{V} \leq V_0 \leq 2\text{V}$		300	$\Omega$
Driver Output Short-Circuit Current			500	mA
Driver Output Slew Rate All Interchange Circuits Control Circuits Rate and Timing Circuits		6 6 4	30	V/ $\mu$ s V/ms V/ms %
Receiver Input Resistance	$3\text{V} \leq V_{IN} \leq 25\text{V}$	3000	7000	$\Omega$
Receiver Input Threshold OUTPUT = MARK OUTPUT = SPACE		-3	3	V V

## “Wimpy” out of spec RS232.

Common in a certain vintage of hardware. Good test is to scope voltage levels, should be beyond (hopefully well beyond) the +/- 3V threshold.

## Port powered anything.

Steals power from data or handshake lines. Adapters with real power inputs are generally much more robust.

**Whenever possible design these out of your system or attach to powered boosters to get real robust RS232.**



# **Taming The Gorilla**

## **RS232 Troubleshooting**

- a) Changing com ports in Windows Device manager  
(Linux, you're on your own).**
- a) Garbled connections: baud, parity.**
- b) Half/full duplex**
- c) Auto Line Feed**

### **Oscilloscope**

- a) What a happy RS232 signal looks like.**
- b) What an unhappy signal looks like.**
- c) Loading down the signal.**
- d) Using crummy cable.**

# ACKNOWLEDGEMENTS

To teachers, mentors, students, and colleagues including

Henry Harrison, David Lucyk, Bob Slavonik,



Trevor Young



Greg Smith



Alex Sneddon



Chris Crosby



Miles Litzmann



Lucas Merlo

and of course my shipmates at RVTEC.

## ONLINE REFERENCES – GUARANTEED TO WORK UNTIL 0000 UTC 10/26/2023

[Archive.org] B&B Electronics Learning Center: Serial connectivity and a whole lot more:

<https://web.archive.org/web/20200227135145/http://www.bb-elec.com/Learning-Center/Serial-Connectivity.aspx>

SparkFun Serial Communications Concepts Tutorial: <https://learn.sparkfun.com/tutorials/serial-communication>

Sparkfun Serial Communications Articles: <https://www.sparkfun.com/search/tutorials?term=serial>

USConverters.com Tech Support Center: [http://www.usconverters.com/index.php?main\\_page=page&id=17&chapter=0](http://www.usconverters.com/index.php?main_page=page&id=17&chapter=0)

Lightning and Surge Protection: <http://www.arcelect.com/lightnin.htm>

WizNet serial to Ethernet: <https://www.wiznet.io/product/serial-to-ethernet/>

## VENDORS AND EQUIPMENT

Advantech 422LCOR RS232 to RS422 converter: <https://iotmart.advantech.com/s/product/bb422lcor/01t1W00009hhR2QAI>

HiLetGo logic to RS232 adapter board (uses Maxim MAX3232 chip): <https://www.amazon.com/gp/product/B00LPK0Z9A>

WizNET RS232 to Ethernet converter: <https://www.digikey.com/en/products/detail/wiznet/WIZ750SR-110/8789614>

Waveshare Ethernet to Serial Server: <https://www.amazon.com/Industrial-Rail-Mount-POE-Multi-Communication/dp/B0BN8GF4PR>

Edgeport USB to RS232 converters: <http://www.digi.com/products/usb-and-serial-connectivity/usb-over-serial-hubs/edgeport>

Starttrch USB to RS232 converters: [https://www.startech.com/Cards-Adapters/Serial-Cards-Adapters/?filter\\_BUSTYPE=USB+2.0](https://www.startech.com/Cards-Adapters/Serial-Cards-Adapters/?filter_BUSTYPE=USB+2.0)

Sparkfun RS485 breakout board: <https://www.sparkfun.com/products/10124>

Adafruit FTDI Friend USB to logic converter: <https://www.adafruit.com/products/284>

Maxim MAX3232 RS232 transceiver: <http://www.mouser.com/ds/2/256/MAX3222E-MAX3246E-99333.pdf>

Sparkfun Logomatic 2 Serial SD Datalogger: <https://www.sparkfun.com/products/12772>

Underwater Kinetics Ultrabox: <https://uwk.com/>

Vishay TransZorb Transient Voltage Suppressors: <http://www.vishay.com/docs/88301/15ke.pdf>

Adafruit Bluefruit E-Z Link Bluetooth to Serial Adapter: <http://www.adafruit.com/products/1588>

RS232 Mini Tester: <https://www.cableleader.com/db25-male-to-female-serial-mini-tester.html>

Mini 9 to 25 adapters:

<http://www.digikey.com/product-detail/en/AB467/AE10291-ND/1630251>

<http://www.digikey.com/product-detail/en/AB470/AE10294-ND/1630254>

Eavesdropping RS232 adapter: <http://www.lammertbies.nl/comm/cable/RS-232-spy-monitor.html>

Anzio Lite Terminal Emulator: <https://www.anzio.com/content/anzio>

Tera Term Pro: <https://ttssh2.osdn.jp/index.html.en>

# Thank you! Questions?

Those attending in person “Please Touch and Handle!”

Thomas C. Wilson, Jr. • [thomas.wilson@stonybrook.edu](mailto:thomas.wilson@stonybrook.edu)

