

# DEEP SUBMERGENCE

SCHEDULING: 2024-2025

## ALVIN / JASON / SENTRY

- Vehicle Overview
- Schedule Process
- Scheduling Tips
- Observations

**ND SF** NATIONAL  
DEEP SUBMERGENCE  
FACILITY



# 2024 Alvin, Jason & Sentry Operation Areas

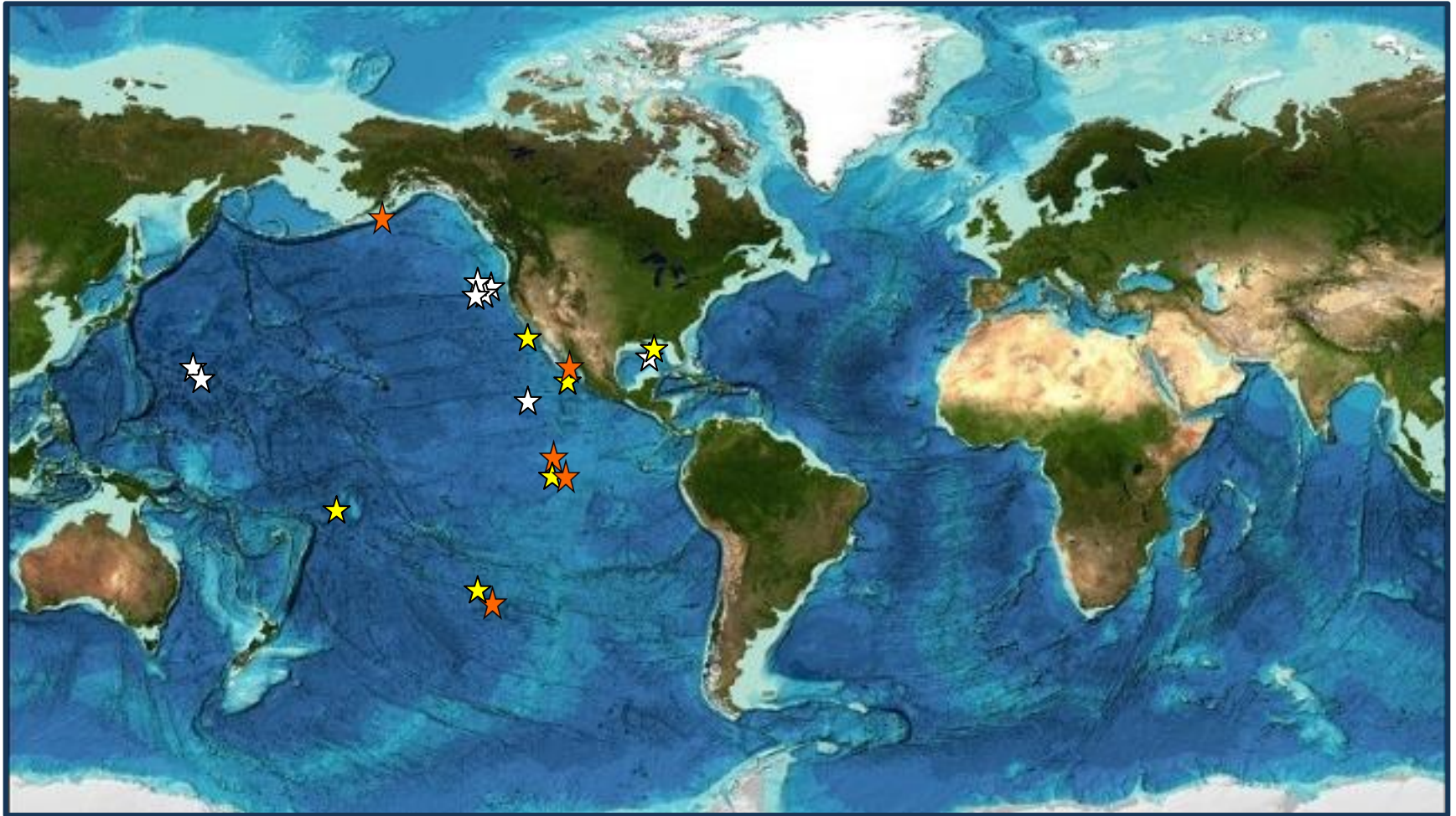

172 *Sentry* days/ 6 Projects – 190 *Jason* days/ 8 Projects – 178 *Alvin* days/ 5 Projects

NDSF

NATIONAL  
DEEP SUBMERGENCE  
FACILITY



# 5 Year Overview

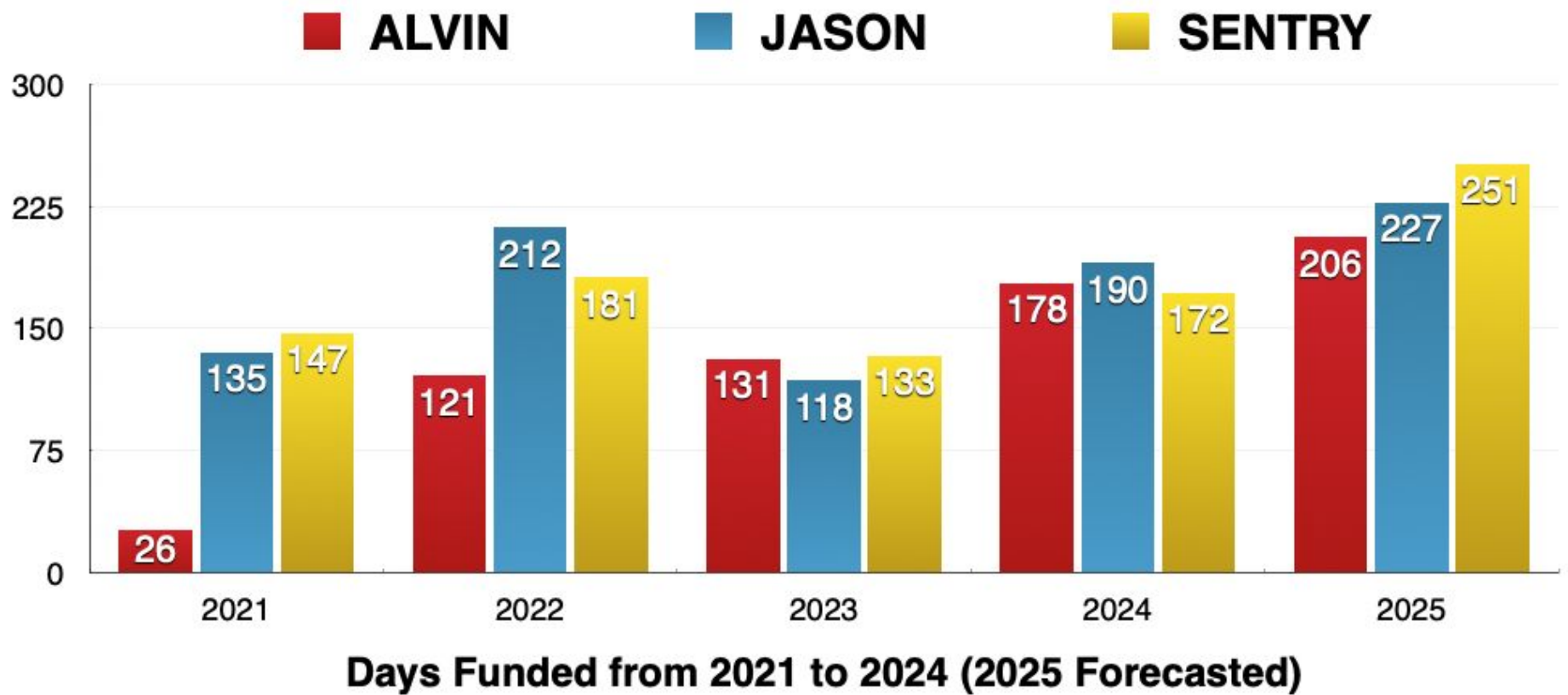

# 10 Year Overview

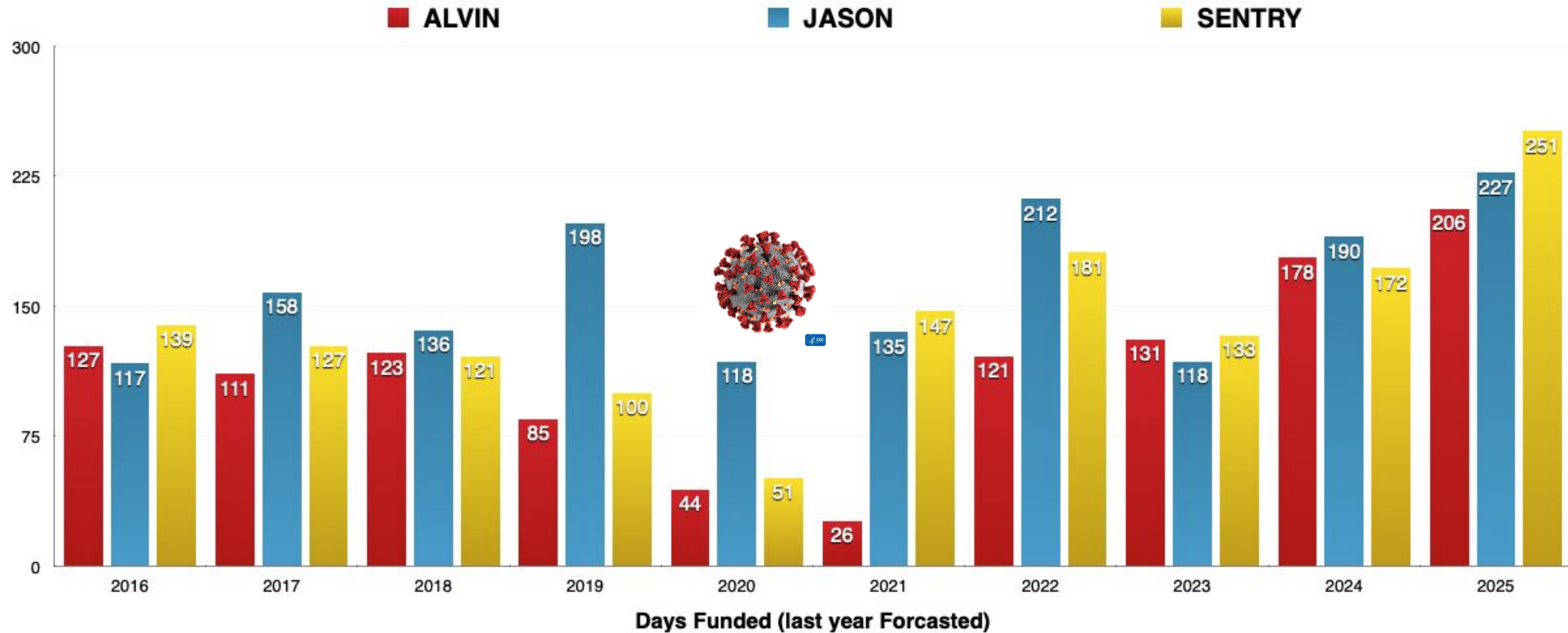



<u>Alvin 2025</u>	
Funded	79
Pending	127
<hr/>	
Total Days	206
Projects	9

(All Alvin only requests)

<u>Alvin 2026</u>	
Funded	0
Pending	29
<hr/>	
Total Days	29
Projects	1

(1 Alvin or Jason)

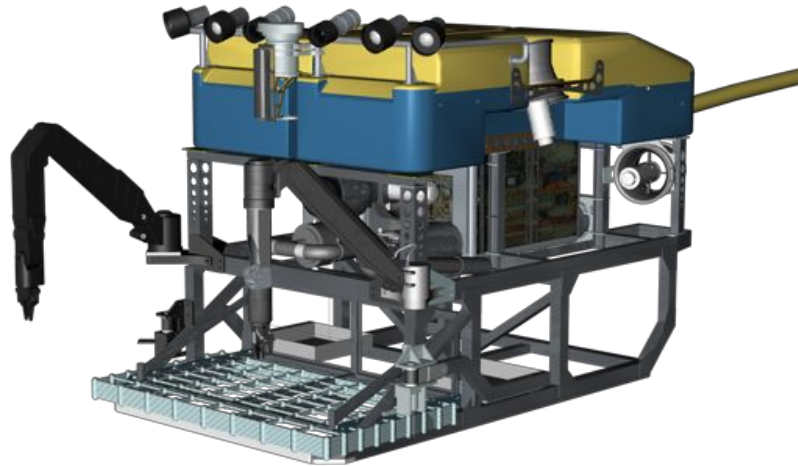

<u>Jason 2025</u>	
Funded	136
Pending	91
<hr/>	
Total Days	227
Projects	9

(All Jason only requests)

<u>Jason 2026</u>	
Funded	57
Pending	18
<hr/>	
Total Days	75
Projects	5

(All Jason only requests)



<u>Sentry 2025</u>	
Funded	215
Pending	36
<hr/>	
Total Days	251
Projects	10

<u>Sentry 2026</u>	
Funded	15
Pending	100
<hr/>	
Total Days	115
Projects	4

# Scheduling Process

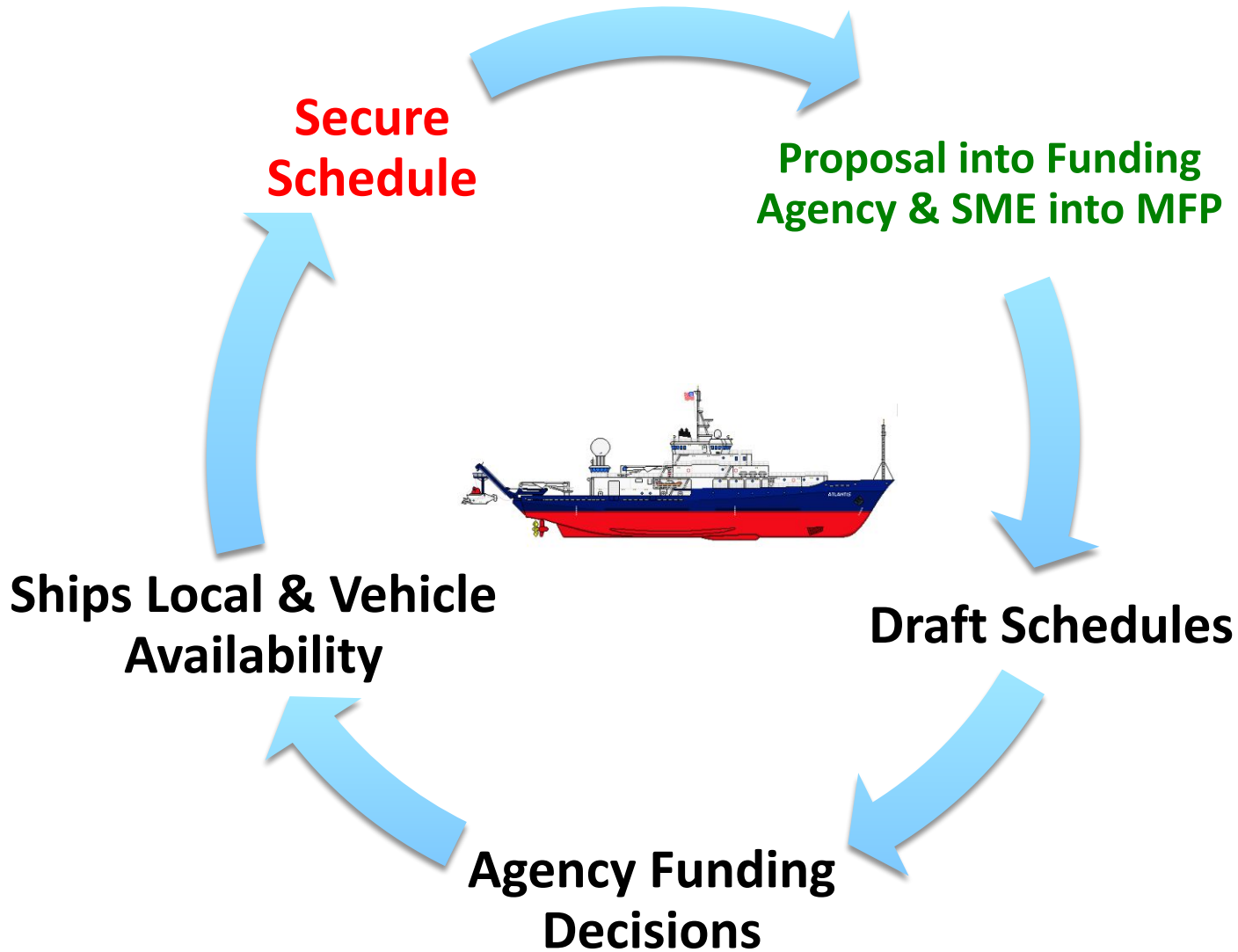



# Scheduling tips...

Jason or Alvin

Check in with  
UNOLS or Ship  
Scheduler

Accurate &  
UPDATED  
SME's

Request your  
VAN &  
WINCHES  
EARLY

Be  
Flexible

Wide  
operating  
windows...  
A +

EARLY State  
Department  
applications

# Observations

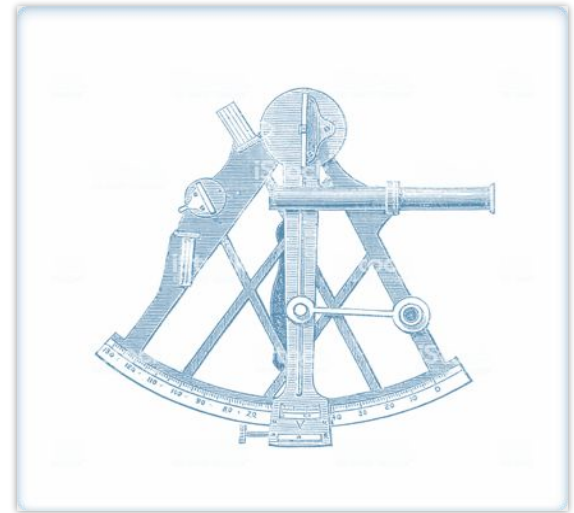

## Vehicles:

- Steady demand for vehicles
- Breaks in-between projects helps w/ crew/ staff retention

## Vessels:

- Endeavor retiring end of 2024 (TBD)
- RCRV's Tani/ Narraganset Dawn ETA ~2025/26
- Revelle coming to USEC to help w/ demand 2024 & 2025 (?)

*Thank you!*



*I'm here to help-*

Kerry Strøm

Senior Manager, Marine Operations

+1 508 289 3938

[kstrom@whoi.edu](mailto:kstrom@whoi.edu)

**NDSF** NATIONAL  
DEEP SUBMERGENCE  
FACILITY

